

300 North La Salle

Liam McNamara
Structural Option

C
h
i
c
a
g
o

Senior Thesis Final Report

Advisor: Dr. Lepage
Spring 2010

300 North La Salle

Project Team

Owner: Hines **Design Architect:** Pickard Chilton Architects, Inc. **Architect:** Kendall / Heaton Assc. Inc **Structural Engineer:** Magnusson Klemencic Assc. **MEP & Fire Protection Engineer:** Alvine and Assc., Inc. **Landscape Architect:** Wolff Clements and Assc. **Civil Engineer:** A. Epstein and Sons International, Inc. **Building Management & Control Systems:** HMA Consulting Inc.

Building Statistics

Cost: \$ 230 million **Stories Above Grade / Total Height:** 58 / 808'6"
Building Occupancy: Office / Retail **Size:** 1.3 million ft²
Construction Dates: June 2008- Feb. 2009 **Delivery:** Design-Bid-Build

Architectural

- 25,000 S.F of column free office space per floor
- Waterfront cafe and restaurant with outdoor seating on riverfront terrace
- Building site is located on north bank of the Chicago River across from the "Chicago Loop" and is a stop of the Chicago Riverboat tours
- Building Envelope is a steel and high-performance glass curtain wall system with a setback above the 42nd floor
- Four level sub-grade parking garage

Structural System

- Structural slab is 3" light-weight concrete on 3" composite deck supported by steel framing
- Lateral load is carried through roof and floor diaphragms as well as a braced frame belt truss to the high strength concrete shear wall core (6-10ksi)
- Foundation consists of drilled bell end concrete piers and driven steel H piles

Mechanical / Electrical / Plumbing

- Serviced by 12kV comed duct bank stepped down to 3000A, 277/480V, 3Φ, 4W, 100% rated
- Offices and cafeteria also have 120/208V sources
- Emergency power provided by a 1750kW standby generator
- Majority of lighting is flourescent with exception of some halogen lighting in the lobby, and exterior metal halides
- 5 Chillers and a shell and tube heat exchanger utilize the Chicago River water to cool and allow for exclusion of cooling towers in system
- Combination of VAV and CAV supply multitude of zones
- Plate and Frame heat exchangers transfer heat to the high zone above level 41

Acknowledgements

I would like to extend my deepest thanks and appreciation to the following individuals and companies:

Hines:

Scott Timcoe

Mike Harrison

Amanda Bridges

Magnusson Klemencic Associates:

Dave E. Eckmann

The Pennsylvania State University:

Dr. Andres Lepage

Robert Holland

Kevin Parfitt

I would also like to give a special thanks to all of my friends and family for their help and support throughout the year.

Table of Contents

Executive Summary	1
300 North La Salle – Introduction	2
Existing Structural System	3
Foundation	5
Gravity System	6
Lateral System	7
Typical Core Plans and Truss Elevations	10
Background	13
Solution	13
Senior Thesis Project Goals	13
MAE Topics	14
Design Criteria	14
Gravity System Design	15
Lateral System Design	16
Initial Layout	16
2 nd Iteration	21
3 rd Iteration	24
4 th Iteration	27
Final Design	30

Coupling Beam Design	31
Pier Reinforcement Design	34
Boundary Elements	38
Foundation Impact	39
Architectural Breadth	40
Acoustical Breadth	44
Conclusion and Recommendation	49
Works Cited	50
Appendix A – Gravity Columns	
Appendix B – Acceleration Calculations	
Appendix C – Coupling Beam Design	
Appendix D – Pier Design	
Appendix E – Wind & Seismic Calculations	
Appendix E – Additional Spreadsheets	

Executive Summary

The purpose of this report is to evaluate the lateral force resisting system designed for 300 North La Salle as part of AE Senior Thesis. 300 North La Salle is a 60-story office building on the north bank of the Chicago River in Chicago, Illinois. The design will be analyzed under wind and seismic loads for strength and serviceability. The architectural and acoustical impacts of the design will also be investigated as part of the report.

300 North La Salle's current gravity system consists of concrete core walls and exterior steel W-shape columns. The floor system is poured concrete slab on top of composite decking. The slab depth is typically 3" light-weight concrete poured over 3" Type W 20 gage galvanized steel decking. The current lateral system is the concrete core. This core spans 120' East to West through 4 bays, typically dimensioned 28'-5" x 42'-9," between 5 North-South walls and enclosed by 2 East-West walls. The core walls vary in thickness from 2'-3" to 1'-6". The core is stiffened at Levels 41 & 43 by a series of 6 outrigger and 2 belt trusses.

The goal of the new proposed design for 300 North La Salle, was to reduce the length of the current core in order to provide more open rentable square footage. The design is a concrete core wall consisting of 2 bays spanning East to West between three coupled I-shape walls. The design process was iterative based on controlling serviceability limits for drift and acceleration.

ETABS models were made of the existing building and the iterations in order to accurately compare the result of the re-design. In ETABS the walls were modeled as shell elements so that they could not take out of plane shear and accurately portrayed shear wall behavior. The floor levels were modeled as rigid diaphragms to transfer the lateral loads into the concrete shear wall core. In the diaphragms attached to the chords of the outrigger and belt trusses various diaphragm constraints were used to accurately gauge their effect on stiffening the core.

The final re-design consisted of the 3 North-South walls and 2 East-West walls and spans 80'. The thicknesses of the new walls range from 2'-0" to 3'-0" reducing in thickness at varying heights. The original outrigger and belt trusses were maintained from the original design and their configuration was altered according to the new plan. Pier and coupling beam reinforcement was designed based on ACI 318-08 Chapters 11, 14 and 21. Pier reinforcement design was confirmed using PCAColumn.

The new design succeeded in reducing the overall length of the core while passing a wind drift limit of $H/400$; a seismic drift limit of $0.02 H_{sx}$; and a peak acceleration limit of 30 milli-g's.

Introduction

300 North La Salle is a 775 ft, 57-story high rise office building located on the north bank of the Chicago River in Chicago Illinois. It contains 1.3 million total square feet with 25,000 gsf of rentable, column free floor space, per level. Construction on the building began in 2006 and was completed in February of 2009 at a cost of \$230 million. It is owned and managed by Hines developers and was designed by Pickard Chilton Architects. The primary tenant is Kirkland & Ellis, Chicago's largest law firm, occupying between 24 and 28 floors. While its primary use is office, 300 North La Salle includes two conference levels, retail spaces, a café and restaurant with scenic views of the river, public spaces and a 225-car underground parking garage.



Fig. 1: Rendering of 300 North La Salle
(Courtesy of Hines)

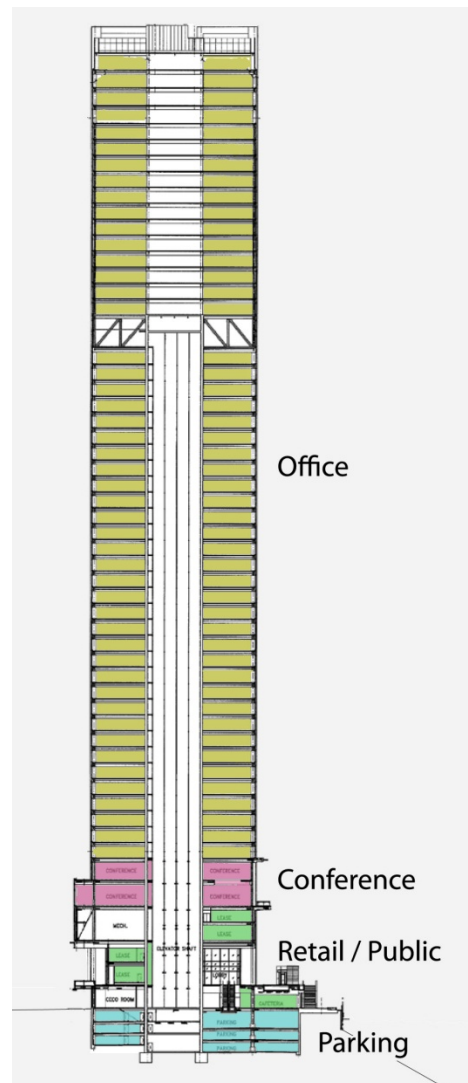

Fig. 2: Space usage of 300 North La Salle
via section cut with Chicago River in
lower right

300 North La Salle boasts a half-acre outdoor waterfront plaza, with 200 feet of frontage along the river. In recognition of 300 North La Salle's entrance into the upper echelon of Chicago architecture and design it was recently added as a stop on the historic Chicago Boat Tour. An evening view from the river can be seen in Figure 3.

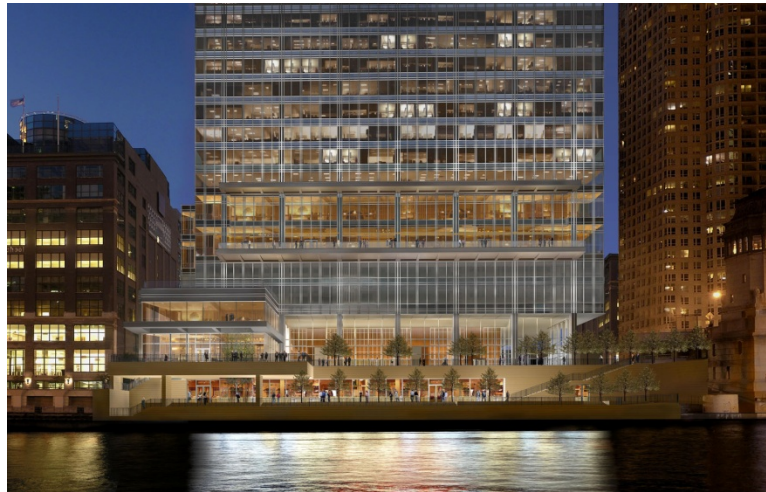

Fig. 3: View from Chicago River
(Courtesy of Hines)

300 North La Salle is an extremely energy efficient building and has been pre-certified as a Gold LEED building. Its glass and stainless steel façade minimizes solar gain while maximizing daylight. Its 9' floor-to-ceiling heights and centralized core structure allow for deeper penetration of the daylight into the spaces reducing the artificial lighting loads. Some other LEED features are its green roof and its promotion of alternative transportation. Alternate transportation is encouraged through the close proximity to the Merchandise Mart metro stop seen in Figure 4 and bike racks on the parking garage levels.

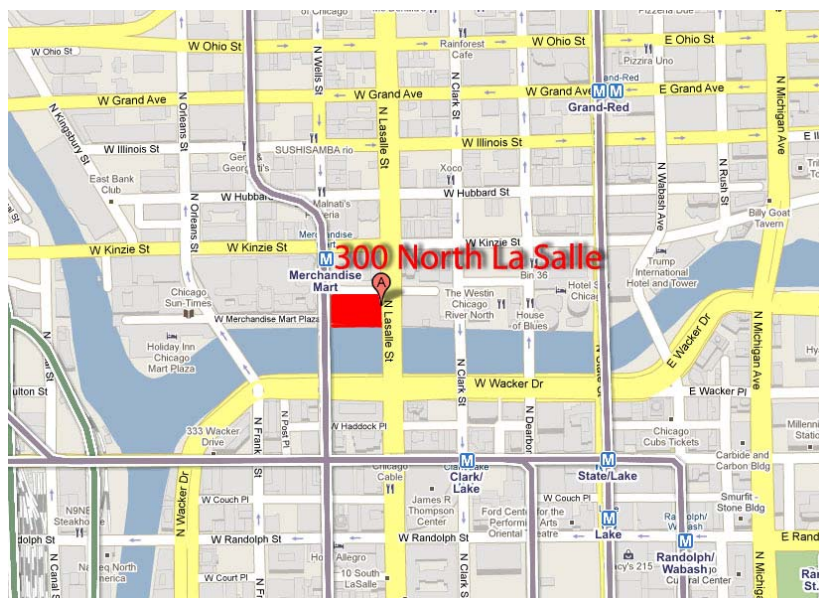

Fig. 4: Location of 300 North La Salle in relation to Chicago transit
(Courtesy of Google Maps)

300 North La Salle incorporates an extensive green roof, Figure 5, a light layer of vegetation on 50% of its roof area. The green roof serves several purposes, it absorbs rainwater, provides insulation and, most importantly for a large city such as Chicago, combats the heat island effect, helping to keep the urban air temperatures lower.

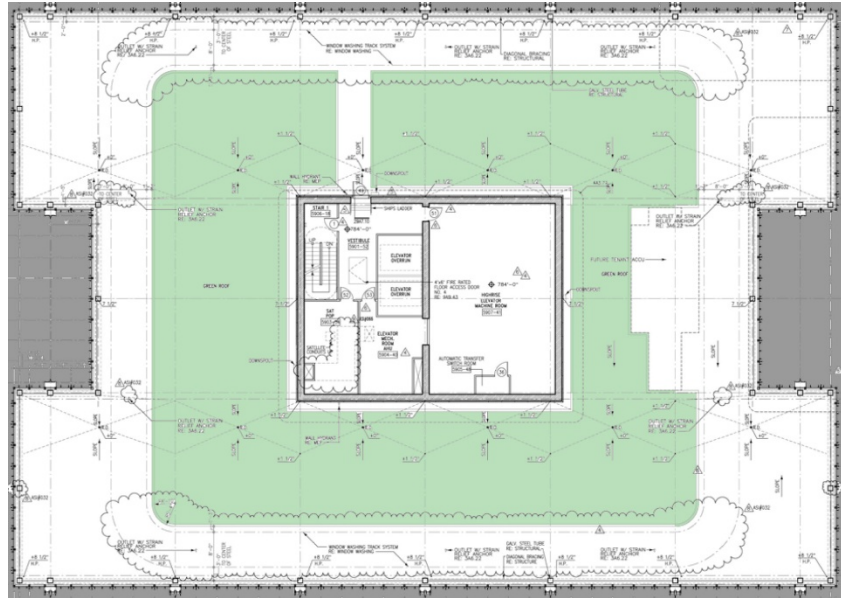

Fig. 5: Extensive green roof plan

Besides using high efficiency glass in the façade, the MEP engineers also utilized water from the river to remove heat from 300 North La Salle's chillers. By using the river water, the mechanical system did not need cooling towers, nor the energy required to run them. The MEP engineering firm Alvine and Associates designed 300 North La Salle to be "approximately 20% under the energy code."

Existing Structure

Magnusson Klemencic Associates were the structural engineers for the design. The superstructure is composed of a concrete bearing wall core and exterior steel W-shape gravity columns. The concrete core is the primary lateral force resisting system, and is stiffened by 6 steel outrigger trusses, and two steel belt trusses all spanning between the 41st and 43rd Levels. The lateral forces are then transferred into the foundation from the moment and shear in the concrete walls as well as axially from the columns which support the aforementioned trusses. The concrete strength of the core varies between 6,000 and 10,000 psi and its wall thicknesses vary between 1'6" and 2'3".

The typical floor system is composite beam with steel decking. It is composed of a 3” cast-in-place concrete slab on a 3” steel deck, and W-shape steel beams. The composite decking is typically 4,000 psi light-weight concrete. The steel members are $F_y = 50$ Ksi except for select columns on the Lower Level that are high strength $F_y = 65$ Ksi steel. The typical bay size is 28.5’ x 45’. The system was chosen to efficiently span the 45’ length creating a column free floor plan between the core and exterior of the building.

Foundation

The building contains 3 sub-grade parking levels, the foundation walls around the parking levels are 18” thick cast-in-place concrete. The foundation of the building is a combination of poured concrete piers and driven steel H-Piles, Figure 6, below a 12” poured concrete slab. The piers are drilled to an approximate depth of 72’ below grade, have top heights between 27’ and 41’, and have a bearing pressure of 40ksf. The piles have a design bearing strength of 270 tons and are driven to refusal in bedrock at an approximate depth of 110’ below grade.

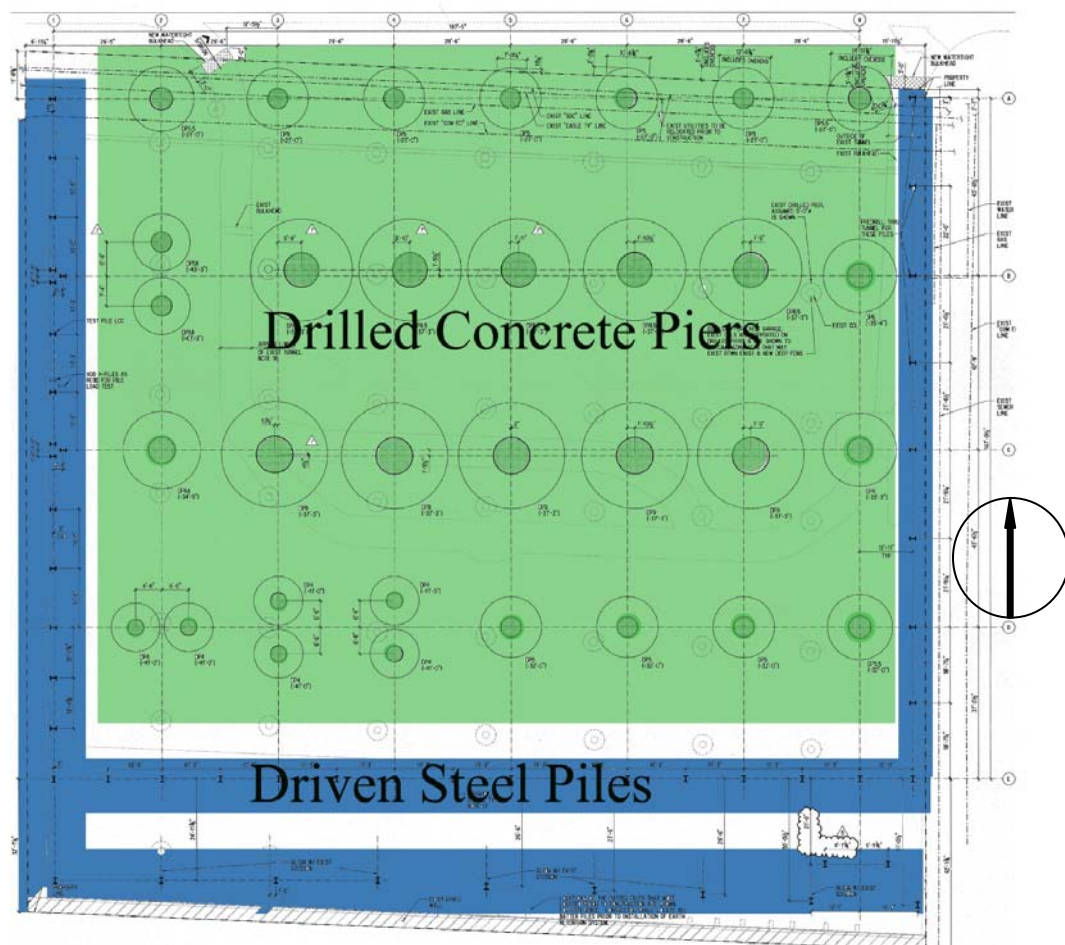

Fig. 6: Foundation plan

Gravity System

The gravity system is a combination of a concrete bearing wall core, and exterior steel columns. The floor system on every floor is poured concrete slab over composite decking, Figure 8. The slab depth varies from 3" light-weight concrete on typical office floors, to 8" normal-weight concrete on mechanical floors. These slabs are poured over 3" Type W 20 gage galvanized steel decking. The composite decking transfers the gravity load onto 50ksi steel wide flange beams are spaced at 9.5' o.c. with typical spans between 42'-9" and 43'-6.5". The gravity loads are then carried to the foundation by the bearing walls and columns as illustrated in Figure 7.

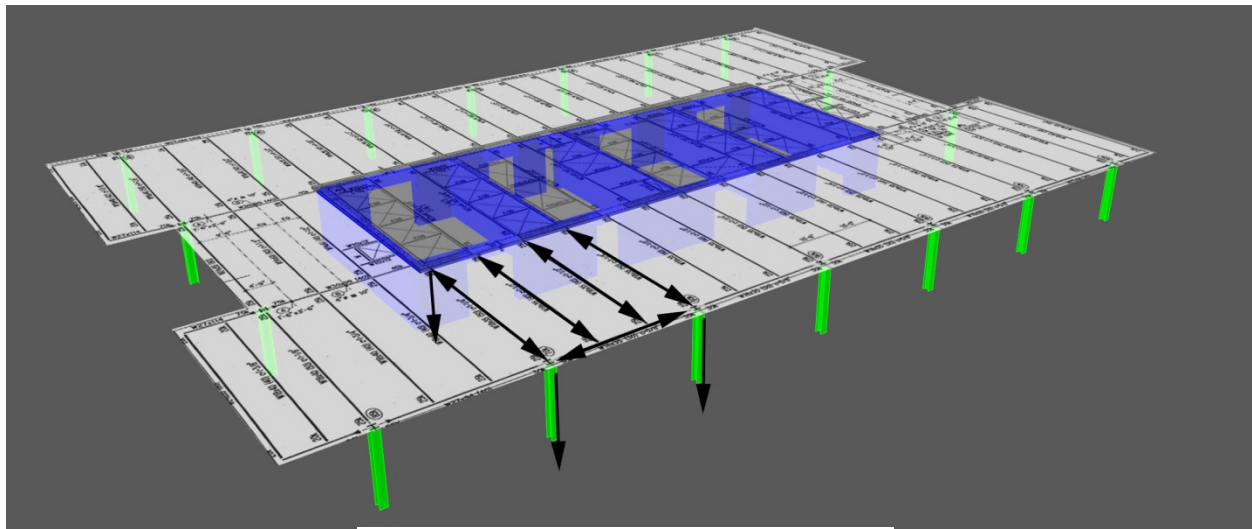

Fig. 7: Gravity Load Path Diagram

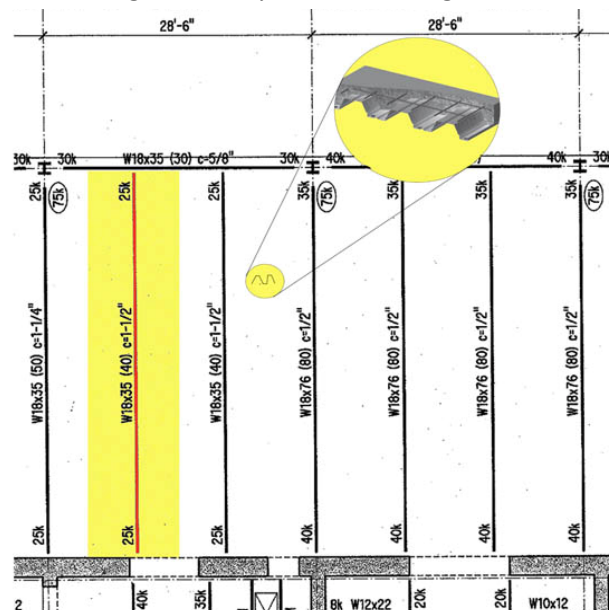

Fig. 8: Typical bay and Composite Deck

Lateral System

Wind and seismic forces are resisted by a concrete shear wall core, strengthened by a series of outrigger and belt trusses between the 41st and 43rd floors. The shear wall core is cast-in-place normal weight concrete of 6,000; 8,000; and 10,000 psi strength depending on location. The wall reduces in thickness and plan as it rises through the building. The thickness of Walls B and C reduce from 2'-3" to 2'-0" at Level 9 and then again to 1'-6" at Level 43. Walls 3-7 have a constant thickness through-out their heights. Walls 3 & 7 are 22" thick and Walls 4, 5, & 6 are 18" thick. The core has four 28'-6" bays spanning east-west as it rises from Lower Level 4 to Level 42, Figure 9, at Level 43 the core drops its outer two walls, Figure 10, and continues through the penthouse with the inner two bays. The floor and roof diaphragms carry the lateral loads to the core walls. The core walls transfer the base shear, overturning moment, and rotational forces to the foundation.

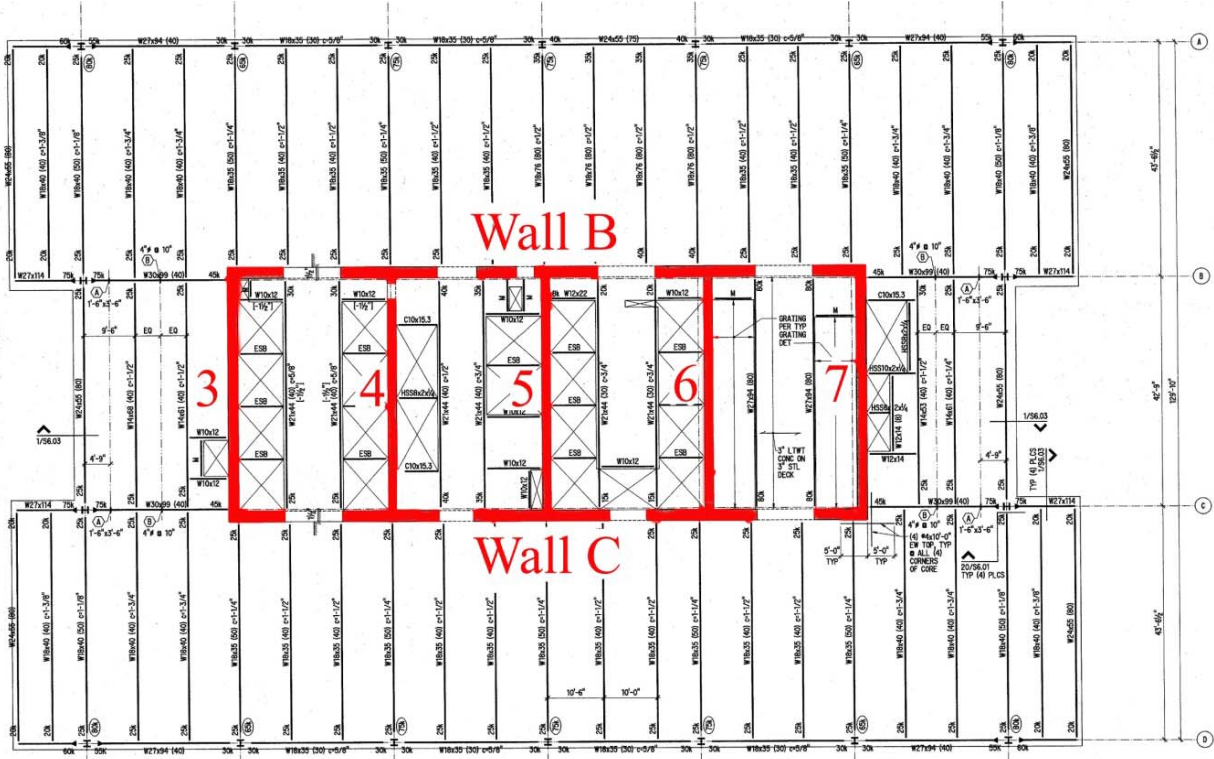

Fig. 9: Core Plan and Wall Name Designation

The building's six outriggers are located on the north and south side of the cores parallel to walls 3, 5, and 7. The belt trusses are comprised of multi-bay braced frames spanning east-west on the north and south exteriors. When the building experiences lateral forces the core deflects like a cantilever. The belt trusses transfer the axial stiffness of the columns below them through the outriggers and into the core. The increased stiffness of the shear wall core at these floors can then be approximated by the area of the columns times the distance from the column to the wall squared ($A*d^2$).

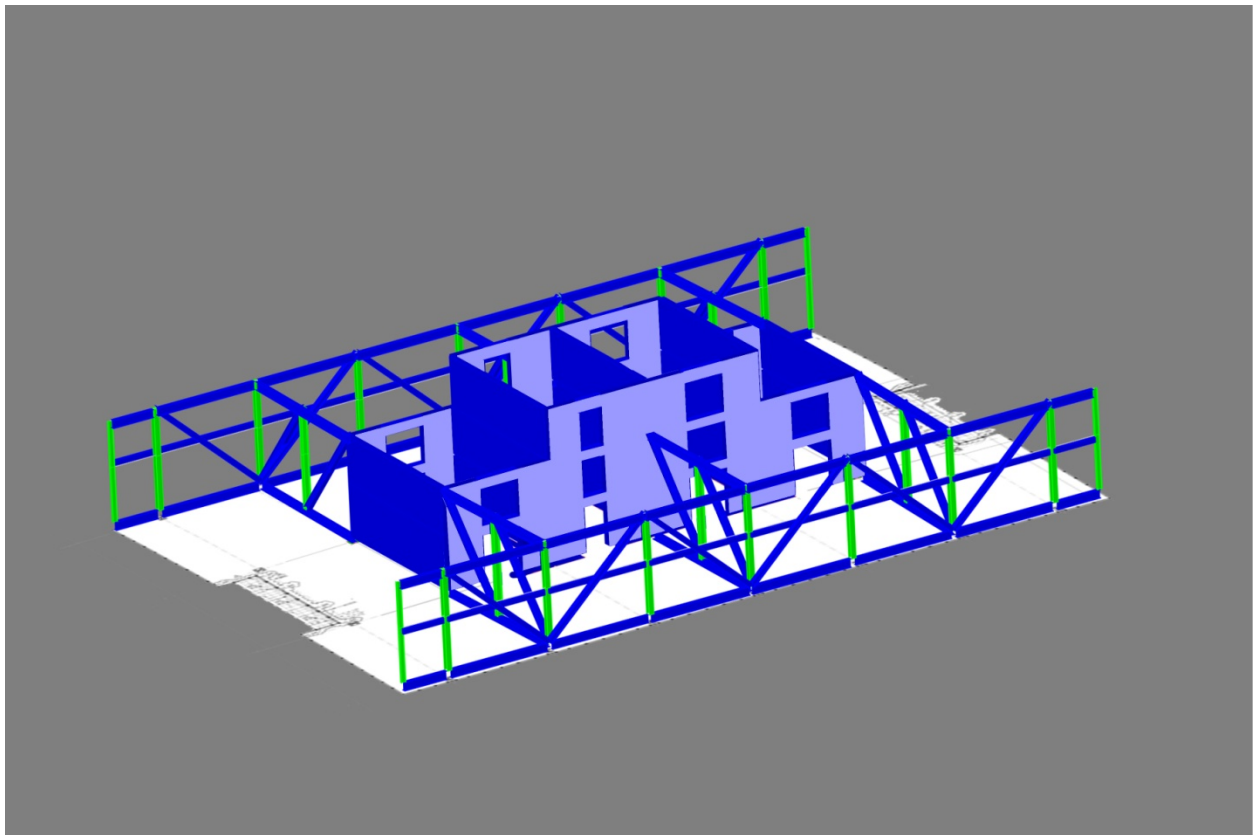

Fig. 10: Outrigger and Belt Truss Location and Configuration as well as core step-back at Level 43

The increased stiffness at these floors act much like a spring, helping to resist the rotation of the core, Figure 11, and therefore reduces the drift of the building under lateral loads.

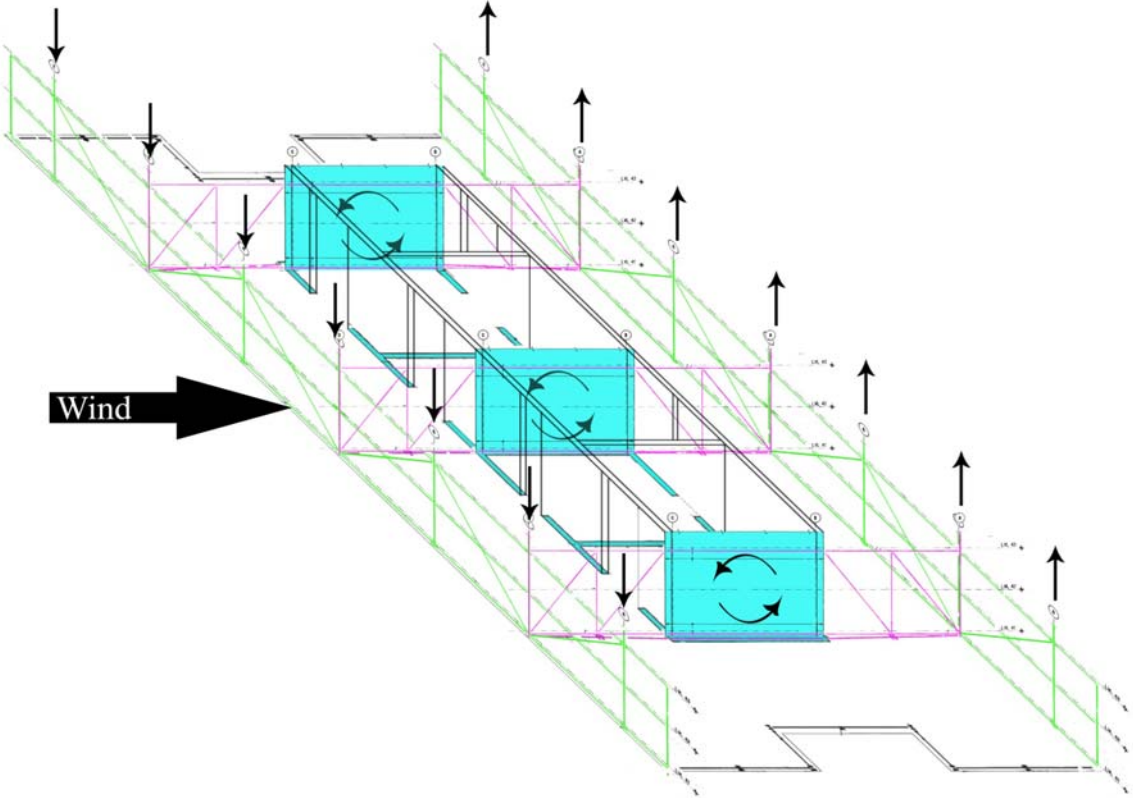

Fig. 11: Truss effects on core and columns under wind loads

Typical Core Plans and Truss Elevations:

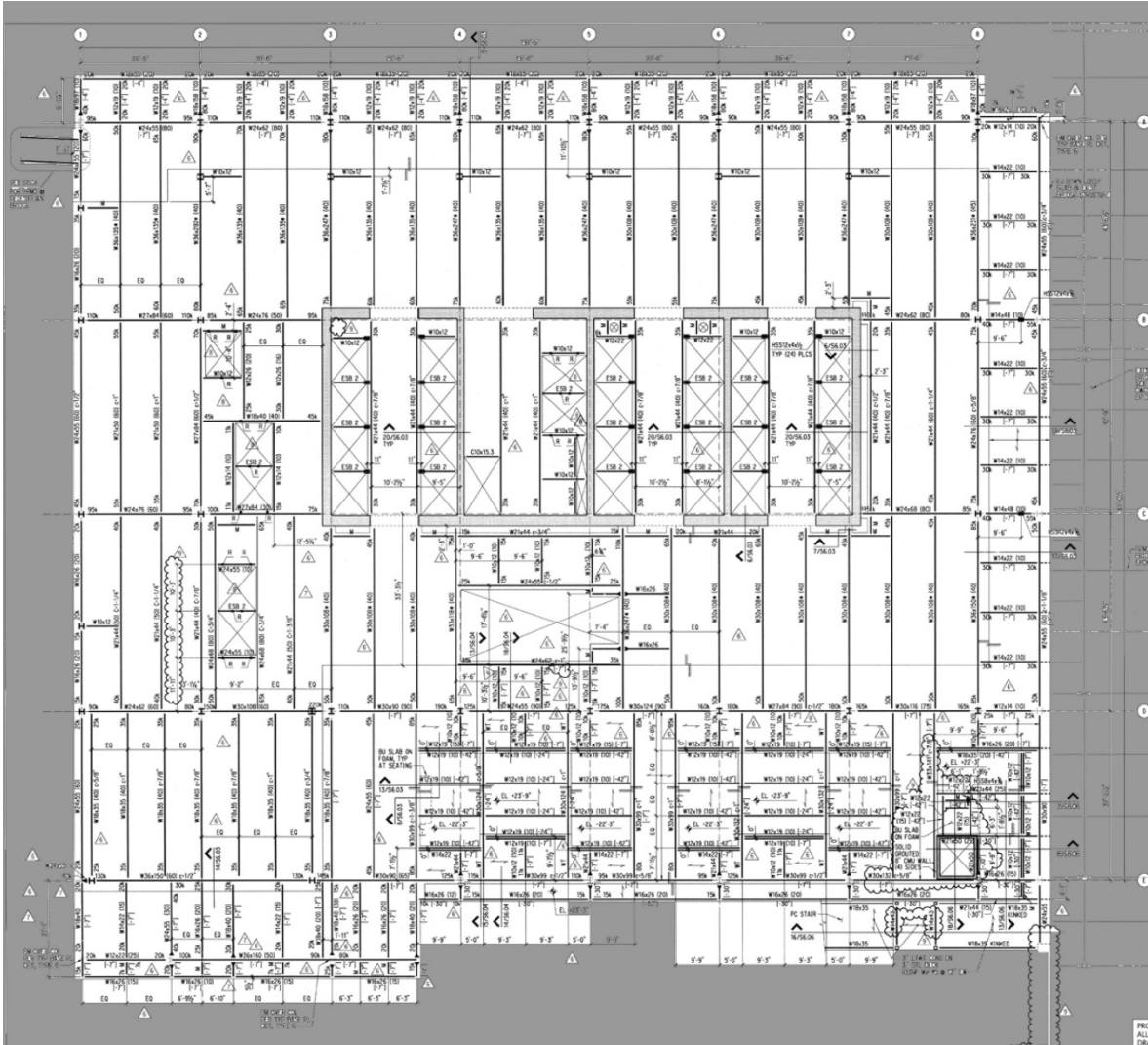

Fig. 12: Structural plan of Lower Level 1

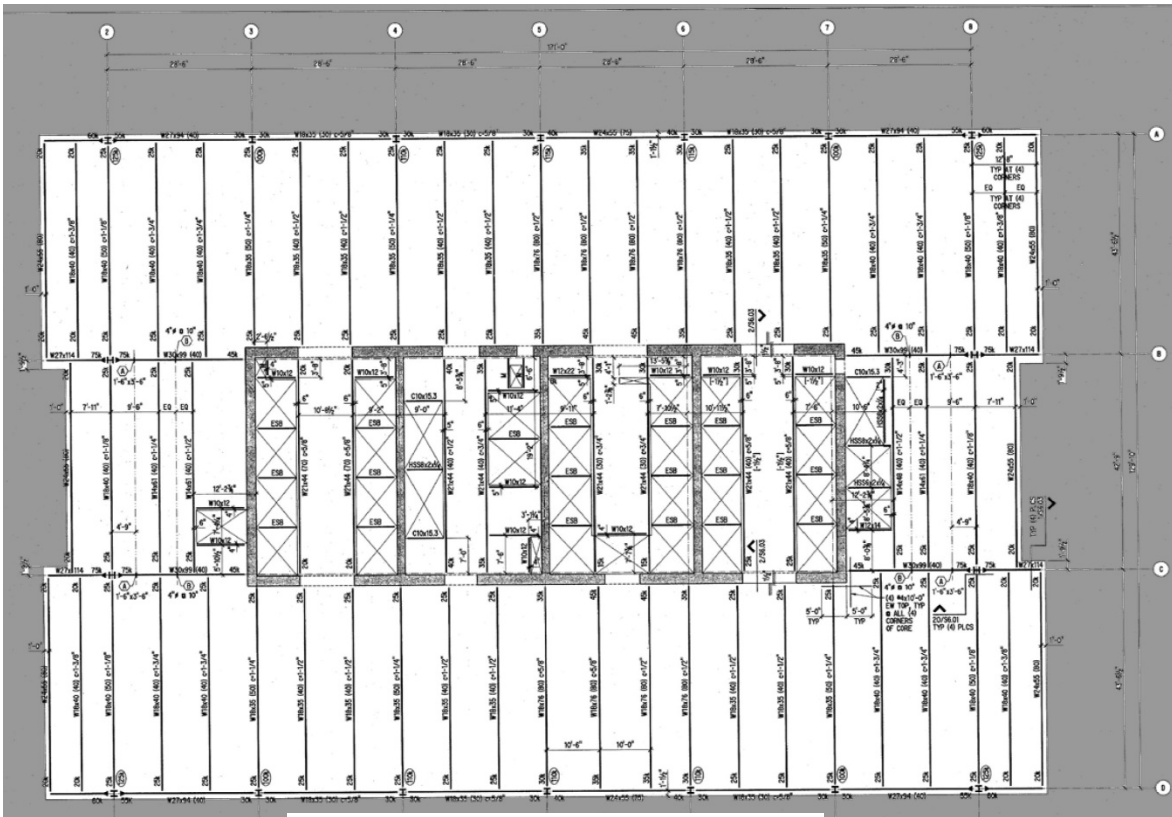

Fig. 13: Structural plan Level 1 – Level 40

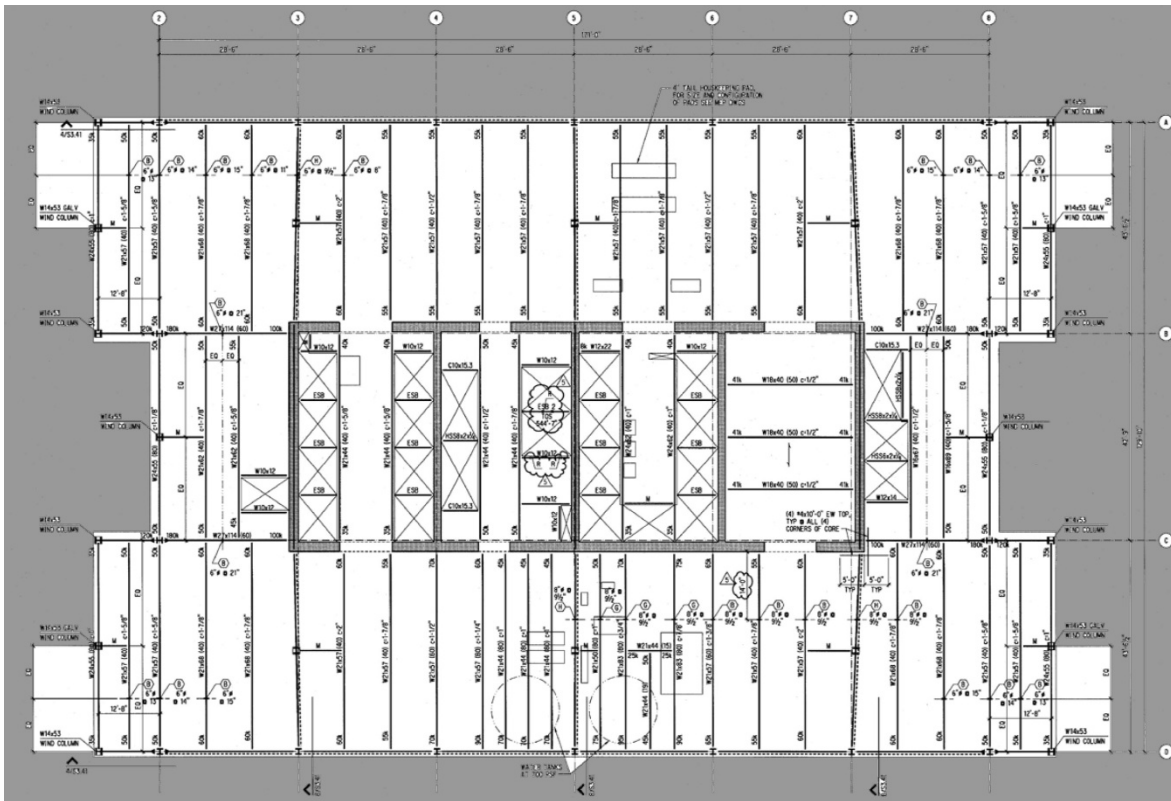

Fig. 14: Structural plan Level 41/ Level 43

Background

300 North La Salle's current lateral system is a reinforced concrete shear wall core with a series of 2-story tall outrigger and belt trusses between the 41st and 43rd floors. The core consists of five walls spanning North-South between a pair of walls spanning East-West creating 4 bays used for vertical transportation such as elevator and stairwell shafts. The shear walls are currently made of 6-10ksi concrete varying in thickness from 18-27 inches. The thicknesses are controlled by the drift of the building under lateral wind loads. The current composite beam floor system assembly typically consists of 3" of light weight concrete on top of 3" metal decking. The deck bears its gravity load on the exterior steel columns and the reinforced concrete core wall and also works as a diaphragm to transfer the lateral loads to the shear walls. After investigating the lateral forces influence on the shear walls it was determined that the overall size of the core could be reduced.

Solution

The building will achieve more net rentable floor space from a reduction in the size of the shear wall core. Upon early inspection it is proposed that reducing the core from 5 N-S walls to 3 thicker N-S walls could reduce the length of the core by up to 28'. Reducing the core to three N-S walls, will also require the outriggers to be moved and re-evaluated.

The shear wall thicknesses can initially be estimated by summing together the thickness of all 5 walls, and dividing it among the three new walls. By keeping the total area of the walls close to the original design, it will ensure that the core can carry the shear loads close to the ground as effectively as the original design. Other than shear checks, the flexural strength of the slimmed down core must be re-evaluated, it is anticipated that the thicknesses of the two walls running East-West will need to be increased. This is because along with carrying the shear in the E-W direction, the walls act like flanges for the N-S walls, and are imperative to resist flexure when loads are applied in the N-S directions.

The changes to 300 North La Salle will then be made to the current ETABS model from Technical Report 3. Various models will be run analyzing the building without the belt trusses, without all of the trusses, and with additional new trusses. These models will be used to investigate the building under design wind and seismic loads and check its deflection and drift against code.

Senior Thesis Project Goals

The main goal of my senior thesis is to reduce the overall length of the core. A Reduction in the size of the core could lead to many economical benefits. For instance a

smaller core could have less material and reduced cost and have more net rentable floor area and increased revenue. The second goal of the project was to become familiar with shear wall and high rise design.

MAE Topics

The MAE requirement for this course will be met by the ETABS computer model of this building. The computer model is reflective of the information taught in AE 597A. The model will be used to evaluate the building under lateral wind and seismic loads. The analysis of the building's seismic drift will also use information taught in AE 538 and AE 597A.

Design Criteria

Design Loads

The design wind loads, applied to 300 North La Salle, were determined using design criteria and data from ASCE 7-05. Primary loads were calculated in the North-South, and East-West directions using Method 2- Analytical Procedure, and referencing "Structural Load Determination Under 2006 IBC and ASCE/SEI 7-05," Flow-charts by David A. Fanella. The design seismic loads were determined using design criteria and data from ASCE 7-05 Chapters 11 & 12 and referencing Chapters 20&21. Flow-chart 6.8 - "Structural Load Determination Under 2006 IBC and ASCE/SEI 7-05," by David A. Fanella was also referenced.

Software

An ETABS model was used to monitor lateral drifts, deflections, and periods of vibration. Output shear, axial, and moment values were also used during the design checks and reinforcement design of the shear walls in the core. PCAColumn was used to check the design reinforcement in the piers via Axial vs. Moment interaction diagrams.

Codes

ASCE 7-05 and IBC 2006 were referenced during the determination of design loads. ACI 318-08 was used during the design checks of the concrete walls, and again during the reinforcement design for the aforementioned walls.

Gravity System Design

In the new design, gravity loads are carried by the concrete core walls and the exterior columns, similarly to the original design. The beams frame into steel girders at the exterior of the building, and directly into the walls on the interior. When evaluating the initial design of the core, it was decided that the concrete coupling beams would be located in a manner so that the steel beams carrying the floor loads would not connect to them and cause additional shear loads.

Engineering judgment was used in confirming the walls bearing capacity. Since the walls thicknesses were all increased from the original design, it is inferred that the walls gain strength and will still be sufficient to carry the gravity loads. The walls experienced the largest axial loads when the load combination $1.2D + 1.6L \pm 1.6W$ was applied. The walls experience a moment from the wind loading which creates additional axial compression loads. The compressive strength of the wall, ϕP_n , was calculated at each level and confirmed to be much larger than the ultimate compression load, P_u . The walls excessive strength in compression is again a testament to the fact that high-rise design is primarily controlled by serviceability. After checking the pure axial loads ϕP_n , the walls were also checked using Axial-Moment Interaction Equations via PCAColumn.

The removal of walls 3 and 7 from the original design created a hole in the gravity path. The new design necessitated that 4 new columns were used per floor at the intersections of grid lines B&C and grid lines 3&7. These columns were designed using "AISC 13th Edition Steel Manual" and ranged from W14x270 at Level 42 to W14x730's that were built-up with additional steel plates at the lowest levels, similar to the exterior columns. These column sizes can be found in Appendix A.

Lateral System Design

Analysis of the existing lateral system demonstrated that the core had excess shear strength in all cases of lateral loading. The buildings core was over designed for strength in order to provide enough stiffness to meet drift and serviceability requirements. The design of the new lateral system was therefore an iterative process examining multiple combinations of core configurations, wall thicknesses, and truss positioning. As the process is explained it is important to note that the strength of the concrete at each level is maintained from the original design so as to remove an extra variable in the process. The following lateral design section will illustrate some of the key iterations; the theory behind them; their results; and the lessons learned, leading to the ultimate final design of the new core.

Initial Layout

Core

The initial step in designing the shear wall core was to determine its layout. After reviewing the initial design, Figure 18, it was determined that the interior two bays would be kept from the original design. The driving factors in the plan layout were to maintain symmetry and to minimize effects on the current architectural plans. Maintaining symmetry about the building's center of mass would minimize the torsion effects, as inherent torsional shear is induced by the eccentricity between the center of mass and the center of rigidity. In order to minimize the effects on the current architecture, the size of the two interior bays were maintained from face to face of Walls 4, 5, & 6.

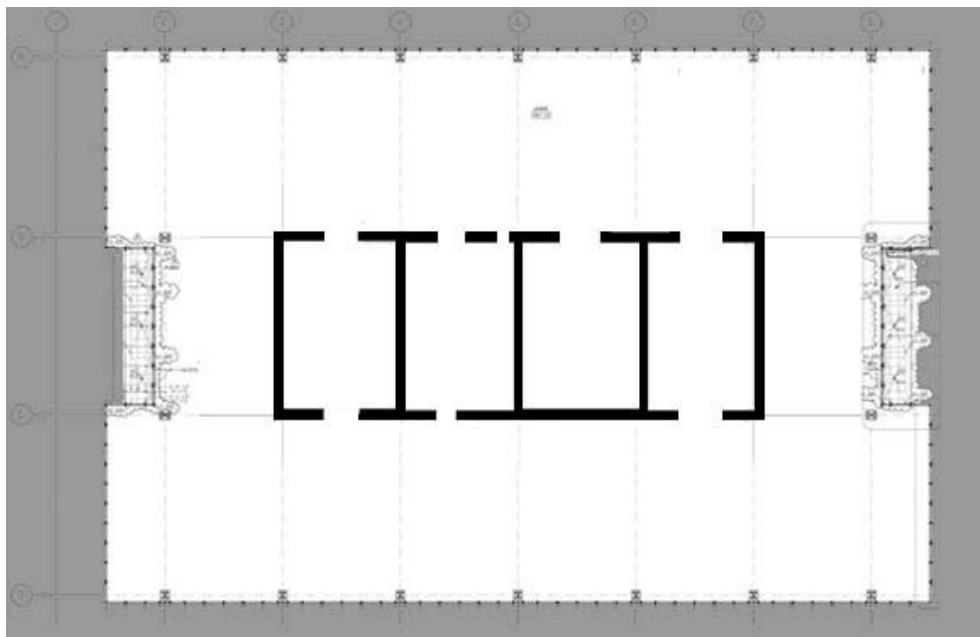

Fig. 18: Original Core Plan – Level 1

The initial wall plan solution consisted of three I shapes spaced in accordance with the original design's 3 interior walls. These I shapes were not perfectly symmetrical, but rather maintained the flanges from the original design. The flanges of the walls, which are also the main EW lateral force resisting system, were to be connected with coupling beams to transfer shear. Referencing the original design it was determined that a 10' wide x 10' high opening was required between each set of flanges to allow access to the elevator shafts they surrounded. Coupling beams span over the 10'x10' openings, and their depth was defined as the distance remaining between the top of each story and the 10' opening. These openings and beam depths can be seen in Figures 20 & 21. The beam depths ranged from 2' to 12' depending on the each individual story height. A lot of concrete area is sacrificed from Wall C between Walls 5&6 from the original design. This wall doesn't have openings until the high rise levels because it surrounds the high-rise elevator core and doesn't require access to the elevators at the low and mid rise levels. These openings were maintained despite the loss to keep each I shape fairly symmetric, increased usage flexibility and create even shear distributions among each wall.

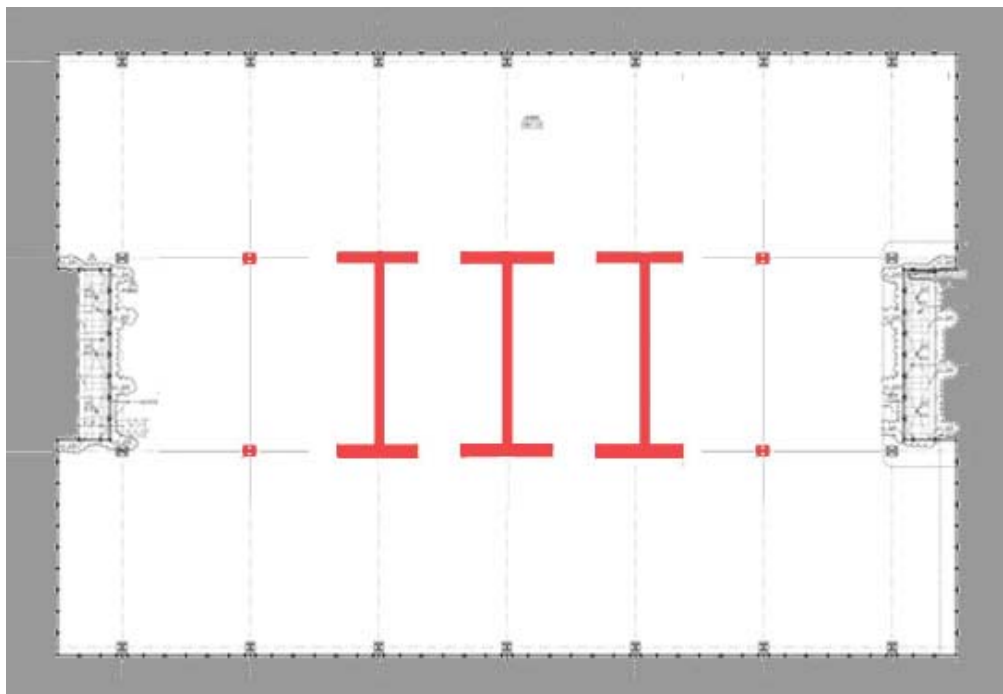

Fig. 19: Iteration 1 Core Plan – Level 1

After determining the proposed core plan, Figure 19, the next step was to determine the wall thicknesses. Since the shear strength of a wall is directly proportional to its area of concrete, the goal was to sum the total area of concrete in each the North-South and East-West directions, and divide it evenly among the new walls. Since the original design was controlled by serviceability drift limits under wind, and not by shear strength, it was assumed that the total could be rounded down where possible. The calculation and distribution of the area

resulted in the 3 North – South walls having a thickness of 30” continuous through the entire height of the building, and the two East-West walls having a thickness of 27” from Lower Level 1- Level 9, 24” from Level 10-Level 42, and 18” from Level 43-Roof. These decreases are consistent in thickness of the East-West walls are consistent with the decreases in the thicknesses of the original design. As labeled in Fig. 19 above.

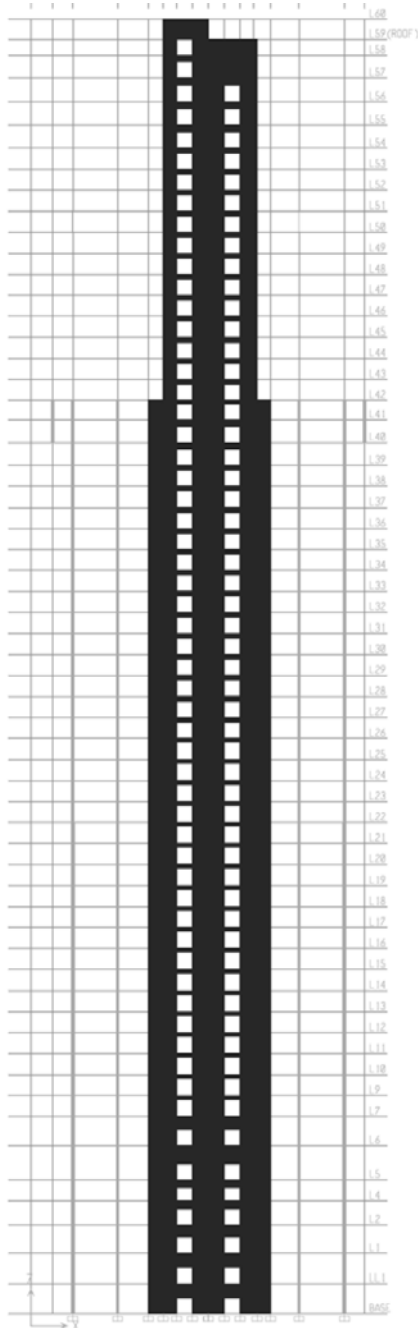

Fig. 20: Wall B Elevation

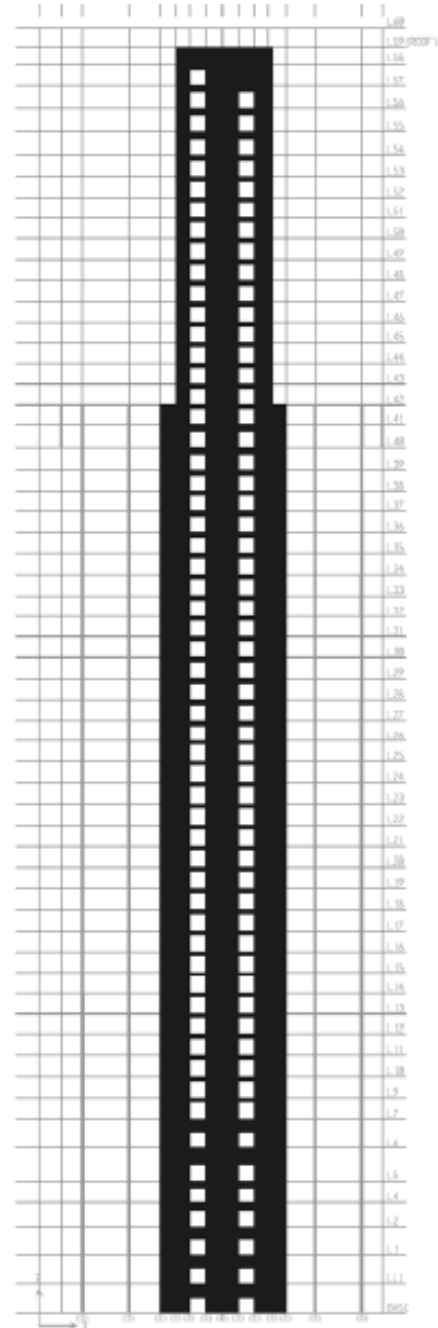

Fig. 21: Wall C Elevation

Trusses

The next step was to adjust the location of the 6 outrigger trusses, 3 on each side of the core. In the original design they were located at Walls 3, 5, and 7. They now needed to be located at the three new walls, 4, 5, and 6 as seen in Figure 22. Before any adjustments were made to the outriggers, it was important to understand their purpose, and how they worked. The outriggers utilize the axial stiffness of the exterior gravity columns to stiffen the core. In order to move the trusses and ensure they were still working as efficiently as in the original design, the columns below them, columns A2, A4, D2, and D4 from Lower Level 1 to Level 43 were repositioned below their trusses new locations. In the new design the columns from the original design on line 3 were switched with the columns on line 4 and the columns on line 7 were switched with the columns on line 6. This transposition would have no effect on their capacity to carry dead and live loads, as their tributary areas remained the same between both designs.

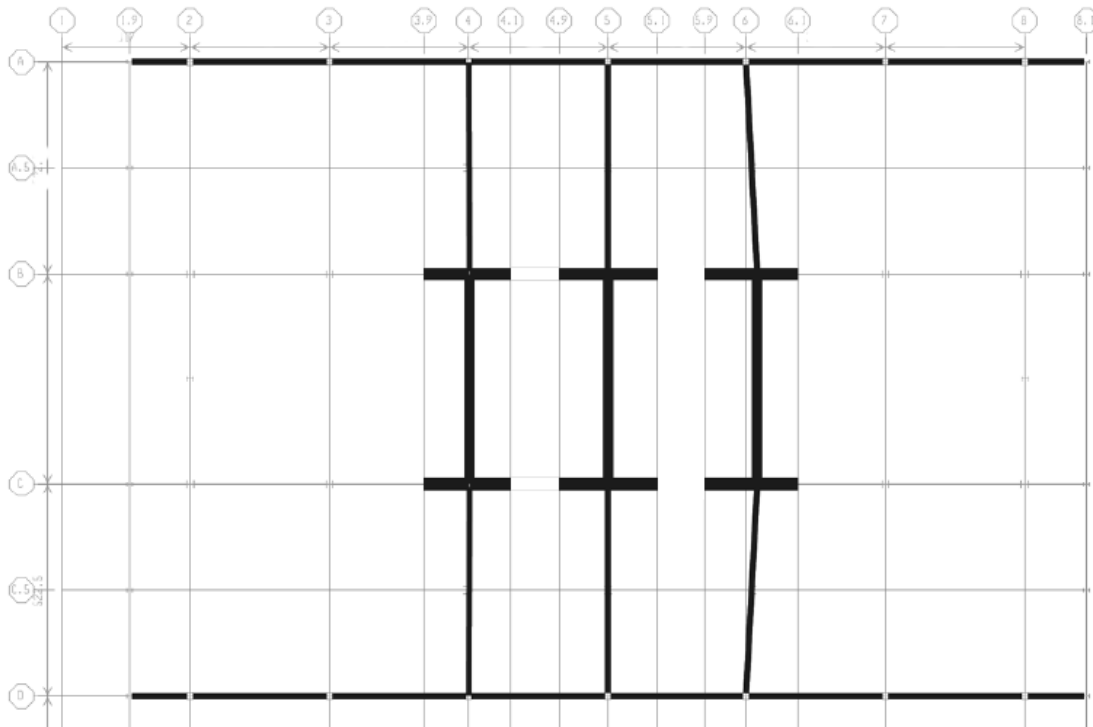

Fig. 22: Iteration 1 Truss Plan

It should be noted that while modeling the new design of 300 North LaSalle for the initial configuration, rigid diaphragms were assigned to Levels 41 & 43. This is important because the rigid diaphragms cause the outrigger and belt trusses to act much stiffer than they would in reality because it causes their top and bottom chords to act with an infinite area. These results were then compared to an ETABS model of the existing structure that also had rigid diaphragms on the aforementioned floors. Since both models maintain the same exterior

columns that would be activated by the outrigger and belt trusses, any change caused by the change in position of the outriggers would be neglected. The comparison of the periods would therefore be directly related to the stiffness of the new core design vs. the stiffness of the original core design.

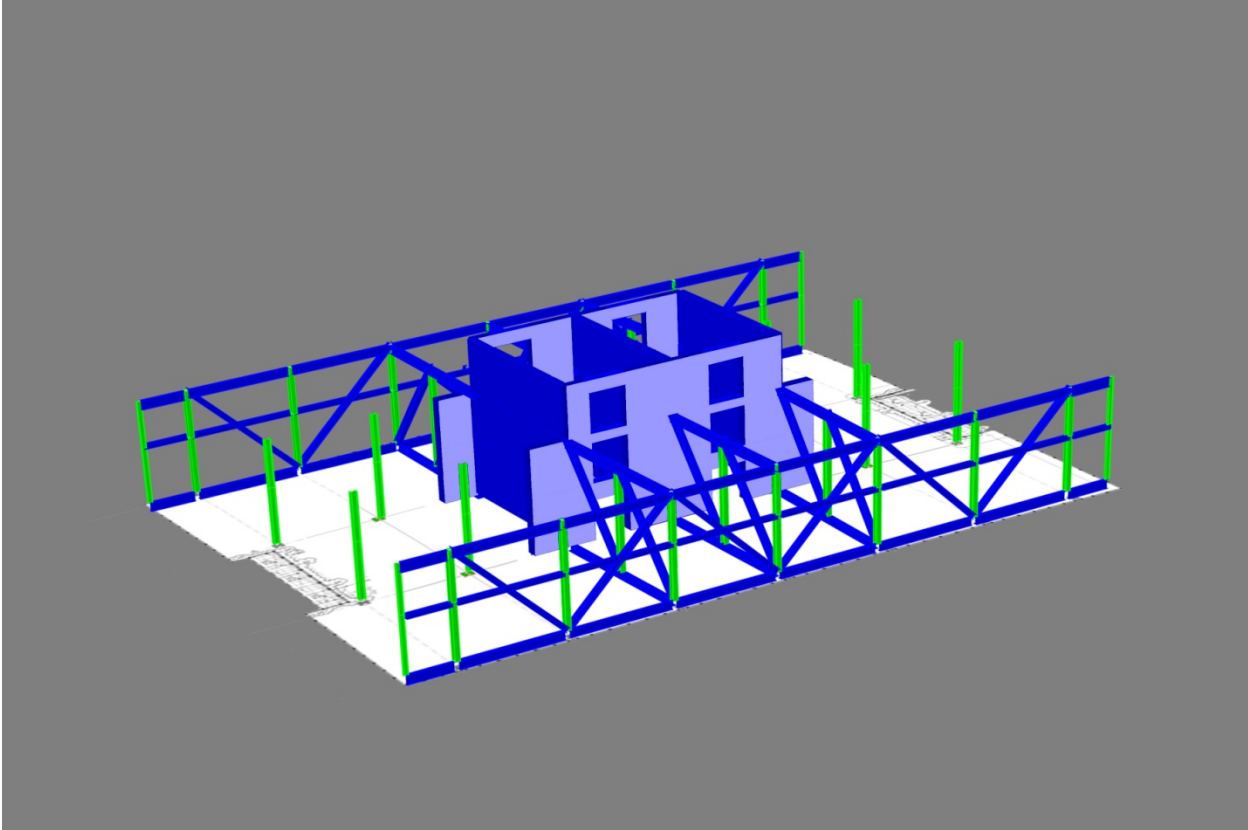

Fig. 23: Iteration 1 Truss and Core Configuration Level 41-43

Results and Analyses

Period of Vibration	Ty	Tx	Tz
Original Model	7.0587	5.7823	5.4727
Iteration 1	7.8236	8.5131	8.3325
% Difference	10.83627	47.22688	52.25574

Table 1: Period of Vibration Comparison: Iteration #1

The initial configuration was then modeled in ETABs and resulted in unacceptably large periods of vibration, Table 1, when compared to the existing building periods. The most noticeable discrepancy was between the periods of vibration in the x-direction, E-W, and the

about the z-axis, torsion. Reducing the length of the walls spanning east to west had reduced the stiffness and resulted in an increase in the T_x and T_z periods of vibration by approximately 50%. This drop in stiffness and resultant increase in periods was considered unacceptable by good engineering judgment. A positive factor in the design was that the T_y , N-S, the controlling direction for drift, had only increased by 10%, leading to the conclusion that the new design is reasonably stiff in the North – South (Y) direction.

Second Iteration

Core

After a few minor iterations with wall thicknesses the next major layout examined involved adjustments to the thicknesses of the three N-S walls at varying levels and the two E-W walls, and an increase in flange lengths for the I-shapes. In reaction to the high periods of vibration T_x and T_z the outer flanges of the I-shapes located on column lines 4 and 6 were increased from 9' to 10', Figure 24. The multiple iterations with thickness variations resulted in the following core configuration; Walls B & C are 33" thick from Lower Level 1 – Level 9, 27" thick from Level 10-Level 42, and 21" thick from Level 43-Roof; Walls 4 & 6 are 30" thick from Lower Level 1 – Level 9, 24" thick from Level 10-Level 42, and 18" thick from Level 43-Roof; Wall 5 is 24" thick through the height of the building.

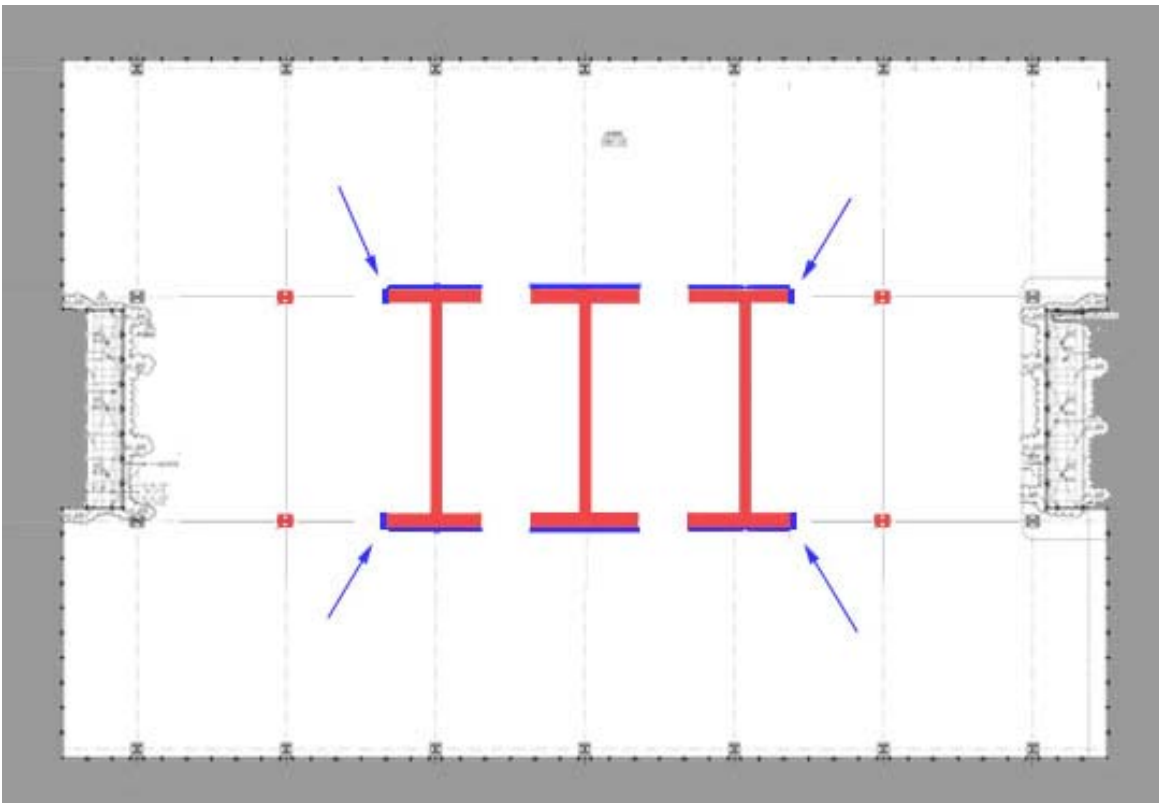

Fig. 24: Iteration 2 Core Plan – Level 1

Trusses

From the analysis of the initial design periods, a new goal was determined to reduce the period of vibration in the E-W (x) direction. To stiffen the core in the E-W direction, 4 outriggers were added on column lines B and C attached to the E-W spanning shear walls seen in Figure 25. These outriggers enact the original exterior gravity columns as well as the newly designed columns that carry the gravity load where the two rows of walls were removed from the original design. The outriggers were roughly sized with a quick hand calculation based on matching the brace stiffness with the axial stiffness of the columns. In an effort to reduce the amount of trusses between the levels, the two belt trusses were also removed during this iteration. The belt trusses were removed under the presumption that the building could have a slightly larger period of vibration in the N-S (y) direction, as long as its periods of vibration in the E-W and about the z-axis were significantly reduced.

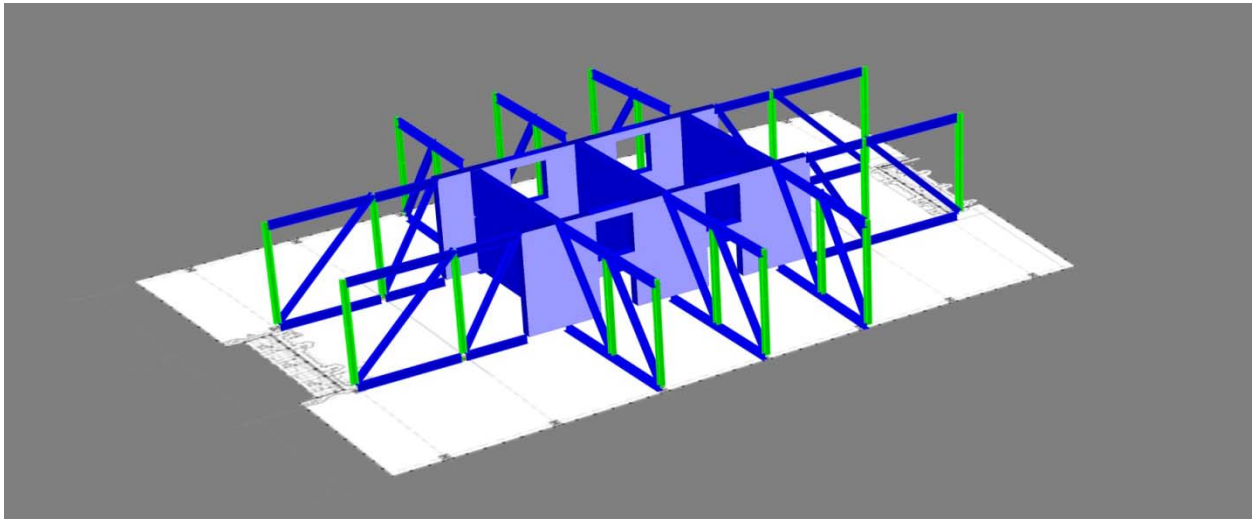

Fig. 25: Iteration 2 Truss and Core
Configuration Level 41--43

It should be noted that due to the elimination of the belt trusses and the introduction of the new outriggers, this diaphragms at Levels 41 and 43 were removed and the masses assigned to them were added to the diaphragms at the levels immediately below and above them respectively. The removal of the diaphragms reduced the effect of the outriggers in stiffening the core. The trusses will now only have the actual area of their top and bottom chords available to stiffen them instead of the infinite area provided by the rigid diaphragms. As the actual stiffening of the core from the outriggers is somewhere between the models with rigid diaphragms and the models with no diaphragms, both were analyzed and compared.

Results and Analyses

The 2nd Iteration succeeded in getting closer to the original design. The average difference between the Periods of vibration in the EW (x) direction and Torsion (z) between the new design and the original reduced from 50% to 30%, and the difference in the NS (y) period of vibration averaged to 5%, seen in Table 2.

	Ty (sec)	Tx (sec)	Tz (sec)	SRSS (sec)
Original Model Flexible	7.85	5.96	5.7	11.39
2nd Iteration Flexible	7.91	7.69	7.51	13.35
% Increase	0.76	29.03	31.75	17.21
Original Model Rigid	7.06	5.78	5.47	10.64
2nd Iteration Rigid	7.77	7.50	7.50	13.15
% Increase	10.08	29.71	37.04	23.57
Average % Increase	5.42	29.37	34.40	20.39

Table 2: Period of Vibration Comparison:
Iteration #2

As the design began to approach the original a new comparative tool was introduced to give a more accurate comparison of the design. This comparative tool proposed evaluation of the new design based on the discrepancy between the Square-root of the Sum of the Squares (SRSS) of the three controlling Periods of Vibration. The SRSS method is derived from seismic analysis and is a way of combining the modal periods of response. It is a conservative way of comparing the responses. The goal was to get the SRSS of the new design within 10% of the original design before moving forward with serviceability checks. The average SRSS of Iteration 2 was 20% and therefore more modifications were required.

The Periods of Vibration in the EW (x) and Torsion (z) were still the targets that had the most need for reduction, and whose increased stiffness would have the greatest effect on reducing the SRSS of the new design.

Iteration 3

Core

After several more minor iterations with wall thicknesses and configuration, the original core layout was reinvestigated with the intent of finding a modification in the core plan that would not negatively affect the original architecture. It was then determined that the openings between the flanges on Walls 2 & 3 could be reduced to 7' wide from 10' wide, Figure 26. The primary use of this bay of the core is not for transportation elevators, but rather for the service elevators and stairwell exits. Therefore there will not be an elevator lobby on each floor requiring wide through ways. This additional 3' of wall in each E-W wall will stiffen them without increasing the overall core dimensions. The new wall configurations are as follows; Walls B & C are 33" thick from Lower Level 1 – Level 9, 30" thick from Level 10-Level 42, and 24" thick from Level 43-Roof; Walls 4 & 6 are 24" thick from Lower Level 1 – Level 42, and 18" thick from Level 43-Roof; Wall 5 is 24" thick through the height of the building. Walls 4 & 6 no longer reduce their thickness until Level 43 to maintain a parallel face within the elevator shafts.

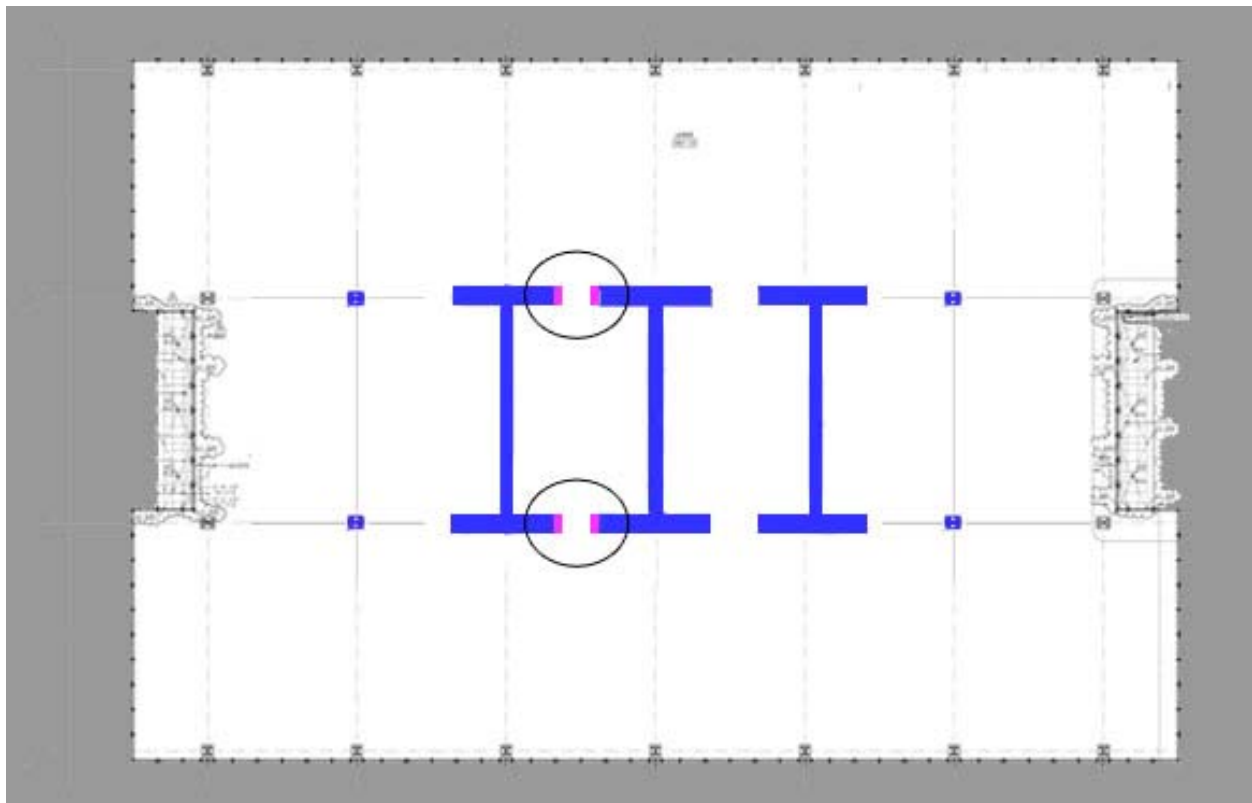

Fig. 26: Iteration 3 Core Plan – Level 1

Trusses

After the success, in the 2nd iteration, of the new EW outriggers, the truss configuration was maintained for the third iteration.

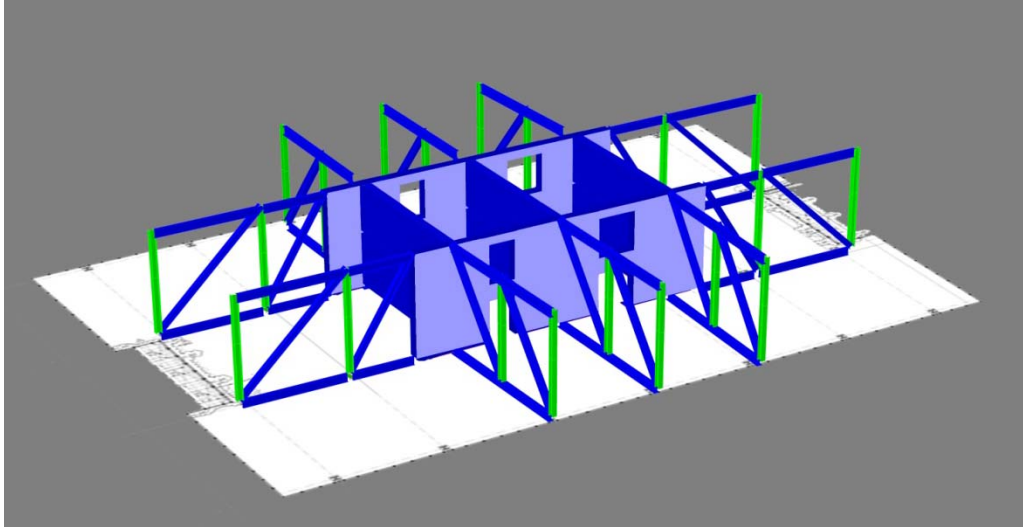

Fig. 27: Iteration 3 Truss and Core Configuration Level 41-43

Results and Analysis

The 3rd iteration succeeded in getting much closer to the original design than the 2nd iteration. An analysis of the SRSS between the 3rd iteration and the original model comparing flexible and rigid diaphragm results yielded an average 13% increase in total period effects, Table 3. These results were much closer to the goal of reaching 10% of the original SRSS. Comparison of the reduction in periods illustrates that while the addition of the wall did not reduce the EW Period of vibration greatly, 6%, it had a significant effect on the stiffness of the building against torsion forces, reducing the period of vibration about the z axis by 20 additional percent. Another observation worth noting is that the 6" reduction in thickness of walls 4&6 at their bottom levels only led to a minor increase in the NS period of vibration. Even though such a large decrease in area of the walls should have led to a large decrease in stiffness, the increase in the flange length added enough stiffness to nearly neglect the effects of the reduction.

Since the 3rd iteration design was very close to the proposed SRSS goal of 10%, third and fourth comparative tools were also used to investigate the new design. In tall buildings there

are two controlling serviceability factors, drift and acceleration. From previous analysis the most critical drift is the drift under wind loads in the NS direction. The drift comparison between the original design and the new design can then be done by a simple spot check of the NS (y) period of vibration. Since the T_y is lower in the new design it can be inferred that the new design will not have lateral drifts larger than the original design, which has already been verified to pass the good design practice drift limit $H/400$.

	T_y (sec)	T_x (sec)	T_z (sec)	SRSS (sec)
Original Model Flexible	7.85	5.96	5.70	11.39
3rd Iteration Flexible	8.10	7.40	6.32	12.66
% Increase	3.18	24.16	10.88	11.20
Original Model Rigid	7.06	5.78	5.47	10.64
3rd Iteration Rigid	7.75	7.11	6.13	12.17
% Increase	9.79	22.96	12.01	14.41
Average Increase	6.49	23.56	11.44	12.81

Table 3: Period of Vibration / SRSS
Comparison: Iteration #3

The fourth comparison is the peak acceleration at the top story of the building under design wind loads. The human body is affected greatly by acceleration forces. A body can adjust to high velocities, such as riding in a car or an air plane, but even the smallest of accelerations (in the milli-g magnitude range) can limit a person’s ability to do work, induce nausea, and cause difficulty walking. The calculations for acceleration were performed using Lawrence G. Griffis’ paper “Serviceability Limit States Under Wind Load” and can be referenced in Appendix B. The range of peak acceleration for a typical high rise office building is between 20 and 30 milli-g’s. Analysis of the original design with flexible and rigid diaphragms yielded peak accelerations between 24 and 25 milli-g’s, Table 4, consistent with the acceptable range. The 3rd iteration’s average acceleration was 29 milli-g’s and it is within 19% of the original design but it is too close to the 30 milli-g upper limit to be considered acceptable.

	A_x (milli-g)	A_y (milli-g)	A_z (milli-g)	A_R -RMS (milli-g)	A_R -Peak (milli-g)
Original Model Flexible	3.12	3.90	4.36	6.63	24.87
3rd Iteration Flexible	3.08	5.68	4.53	7.89	29.60
% Increase	-1.32	45.70	3.84	19.01	19.01
Original Model Rigid	2.89	3.81	4.23	6.38	23.93
3rd Iteration Rigid	3.09	5.12	4.61	7.55	28.31
% Increase	7.14	34.33	9.04	18.32	18.32
Average Increase	2.91	40.01	6.44	18.67	18.67

Table 4: RMS and Peak Acceleration
Comparison: Iteration #3

Iteration 4

Core

After a multitude of thickness variations were attempted to further reduce the periods of vibration it was determined that the walls would be increased to the greatest thicknesses that could be afforded before too greatly impacting the existing architecture of the core. The plan configuration of the core remained the same from iteration 3 still utilizing the decreased opening sizes. The core thicknesses are as follows: Walls B & C are 36" thick from Lower Level 1 – Level 9, 33" thick from Level 10-Level 42, and 27" thick from Level 43-Roof; Walls 4 & 6 are 27" thick from Lower Level 1 – Level 42, and 24" thick from Level 43-Roof; Wall 5 is 24" thick through the height of the building.

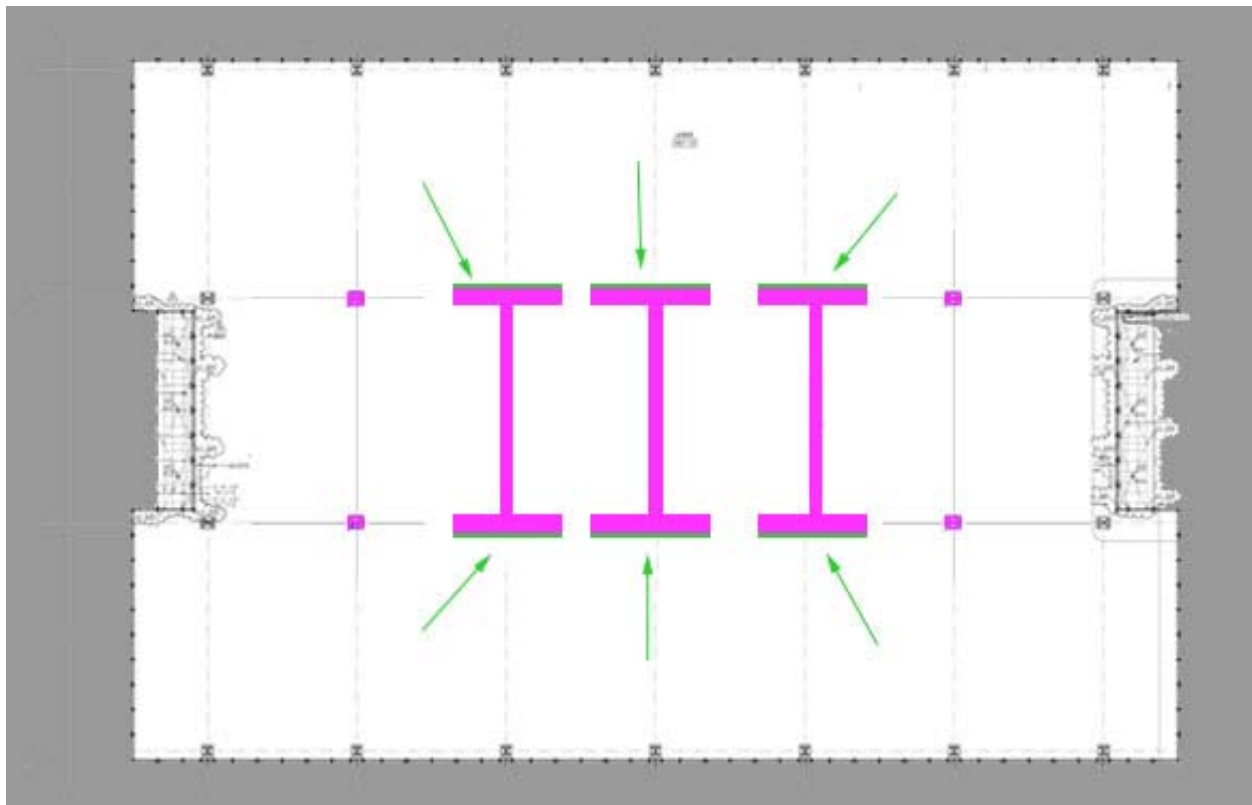

Fig. 28: Iteration 4 Core Plan – Level 1

Trusses

The multiple iterations of increased core wall thicknesses still were not providing results within the 10% target SRSS range. The major decision here was to reinstate the use of the original belt trusses and eliminate the E-W outriggers from iterations 2 and 3. This decision was based on a couple key factors. The first factor was that the walls were at the limit of their thicknesses, and any further stiffness from the walls would require an increase in the length of

the core walls. This was undesirable because the purpose of the thesis was to reduce the overall length of the core. The belt trusses would provide stiffness from all of the exterior columns on the North and South facades. These columns were also farther from the center of the building than the columns below the 4 E-W outriggers. Therefore their effect would be much greater due to the property of stiffness based on area times distance squared ($A*d^2$). The second factor in the decision to eliminate the E-W outriggers for the belt trusses was the increased E-W wall area gained during iteration 3 from decreasing the opening sizes. The increased wall area had increased the stiffness against torsion so greatly, while also increasing the stiffness in the E-W direction that the outriggers may no longer have had a great impact.

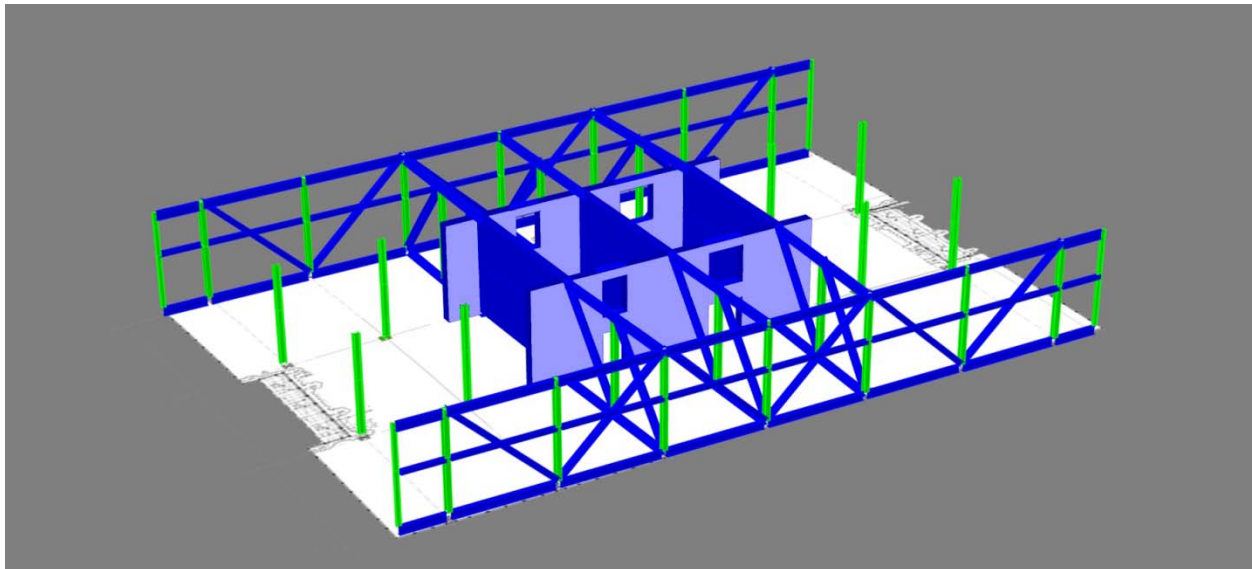

Fig. 29: Iteration 5 Truss and Core Configuration Level 41-43

Results and Analysis

The fourth iteration succeeded in having an average SRSS within 10%, Table 5, of the original design and again had an acceptable drift because its controlling period of vibration is

	Ty (sec)	Tx (sec)	Tz (sec)	SRSS (sec)
Original Model Flexible	7.85	5.96	5.70	11.39
4th Iteration Flexible	7.71	7.61	5.99	12.38
% Increase	-1.78	27.68	5.09	8.72
Original Model Rigid	7.06	5.78	5.47	10.64
4th Iteration Rigid	7.38	7.12	5.95	11.86
% Increase	4.55	23.13	8.72	11.43
Average Increase	1.38	25.41	6.90	10.07

Table 5: Period of Vibration / SRSS Comparison: Iteration #4

within 1.5% of the original. The accelerations were calculated and their average was approximately 17% higher than the original design, Table 6. This average acceleration was 28.6 milli-g's. The results from models with either two flexible or two rigid diaphragms for Levels 41 and 43 were appropriate to produce a range between extreme behaviors of the trusses to use for comparison but further analysis could be performed with a semi-rigid diaphragm.

	A _x (milli-g)	A _y (milli-g)	A _z (milli-g)	A _R -RMS (milli-g)	A _R -Peak (milli-g)
Original Model Flexible	3.12	3.90	4.36	6.63	24.87
4th Iteration Flexible	3.20	5.44	4.61	7.82	29.32
% Increase	2.35	39.55	5.76	17.88	17.88
Original Model Rigid	2.89	3.81	4.23	6.38	23.93
4th Iteration Rigid	2.98	5.13	4.51	7.45	27.94
% Increase	3.33	34.62	6.60	16.76	16.76
Average Increase	2.84	37.09	6.18	17.32	17.32

Table 6: RMS and Peak Acceleration
Comparison: Iteration #4

The fourth iterations compliance with all four comparison goals required that a more accurate model representation was necessary. The diaphragms on Levels 41 & 43 were now modeled as semi-rigid diaphragms. Semi-rigid diaphragms utilize material properties of the floor system as well as area meshing to produce a model more representative of actual behavior. The ETABs model of the 4th iteration utilizing semi-rigid diaphragms on the aforementioned levels yielded an acceleration of 28.2 milli-g's. Within the 10 milli-g typical range for high rise office buildings, 20-30 milli-g's, this is almost 20% below the upper limit, and is therefore considered acceptable. The acceptance of the 4th iterations acceleration confirmed the new design was final.

	A _x (milli-g)	A _y (milli-g)	A _z (milli-g)	A _R -RMS (milli-g)	A _R -Peak (milli-g)
4th Iteration- Semi Rigid	2.99	5.22	4.51	7.51	28.18

Table 7: RMS and Peak Acceleration Semi-Rigid Diaphragm

Drift analysis under seismic and wind loads can be found in Appendix E. The maximum drift from wind was 22" at 760' and was under the recommended limit of h/400 at all levels. The seismic drift, a strength requirement, was well under the code limit of 0.02hsx.

Final Design

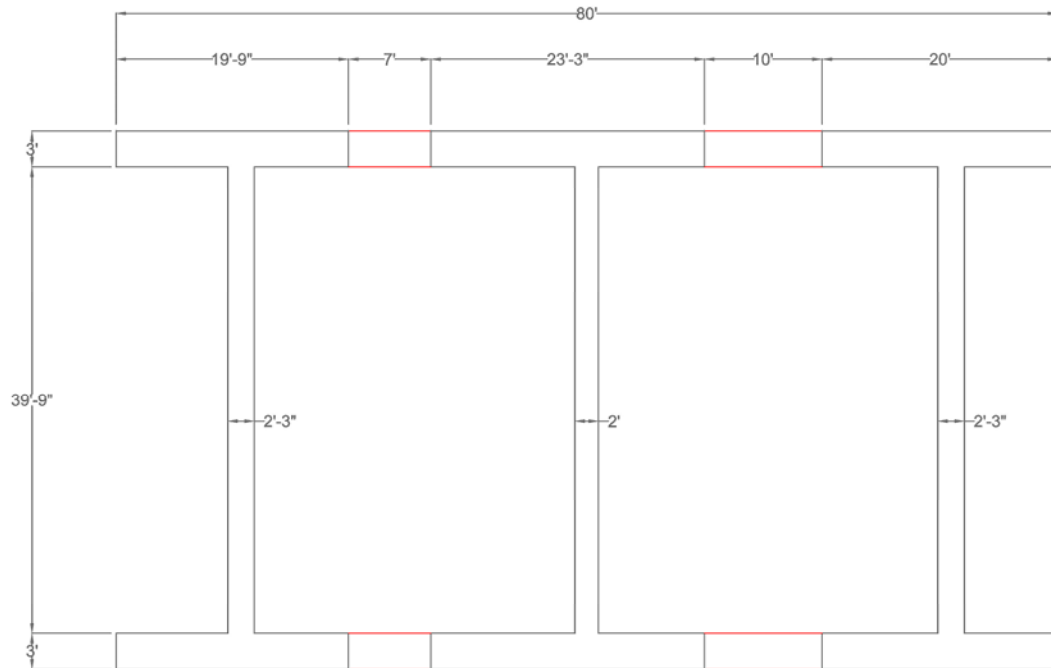

Fig. 30: Final Design Core Plan: Lower Level 1 – Level 9

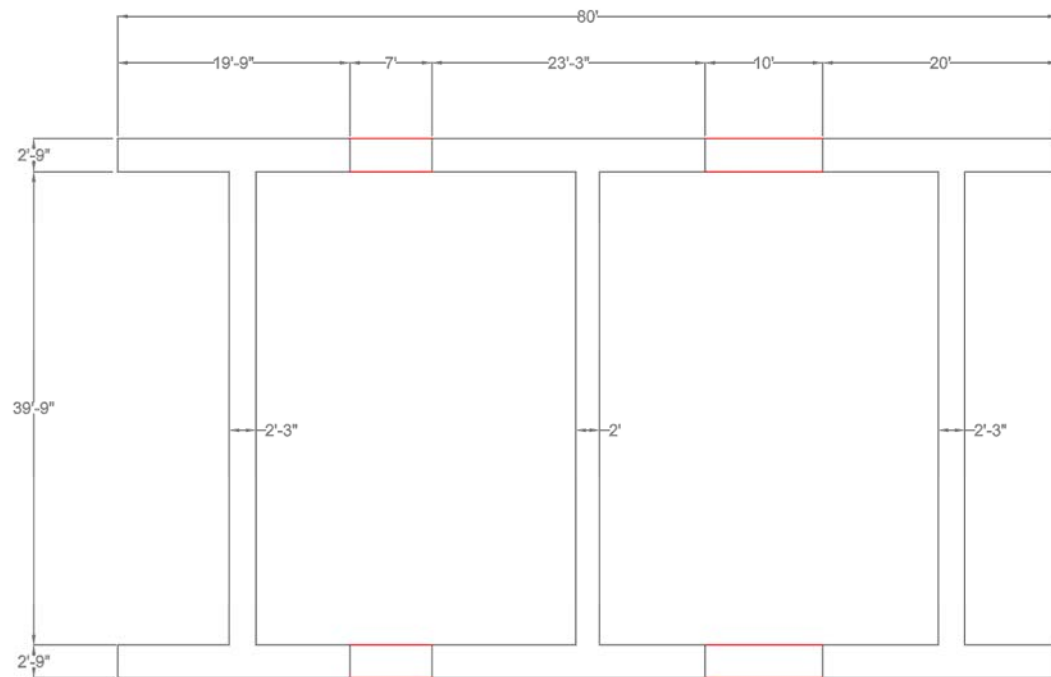

Fig. 31: Final Design Core Plan: Level 10 – Level 43

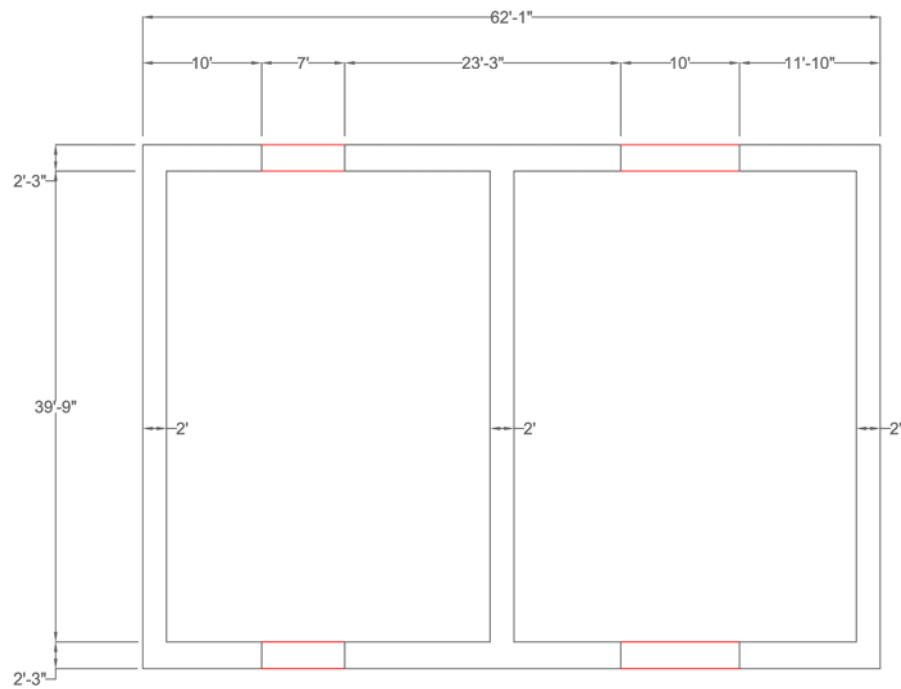

Fig. 32: Final Design Core Plan: Level 43 – Roof

The next step in the design of the new shear wall core was to design the reinforcement of the walls. Moments and shears were acquired from the ETABs model, and combined with calculated dead loads to find the controlling combination. The stresses from the controlling load combinations were then used to design vertical and horizontal shear reinforcement as well as flexural steel reinforcement.

Coupling Beam Design

When designing the coupling beam reinforcement, the code allows a 20% reduction in max shear when grouping the beams. The design moment is then the larger of the 20% reduced max moment, which is equivalent to a 20% reduction in shear, and the average moment of the grouping. This grouping is done to insure that no individual beam is over reinforced compared to those around it, leading to a shear failure instead of a flexural failure during a seismic event. The beams were organized into four primary groups with outliers designed individually. These groups were broken down as follows; Group A: spanning Pier 4 – Pier 5 & ranging from Level 43-55; Group B: spanning Pier 4 – Pier 5 & ranging from Level 9 – 39; Group C: spanning Pier 5 – Pier 6 & ranging from Level 43 – 55; Group D: spanning Pier 5 – Pier 6 & ranging from Level 9 – 39. In all four groups the 20% reduced max moment was the controlling moment.

	Mavg	0.8 Mmax	Vu
Group A	-4610.9	-5104.6	-54.9
Group B	-20204.8	-21449.5	-240.5
Group C	-7346.3	-7507.0	-61.2
Group D	-23827.7	-23968.2	-198.6

Table 8: Shear Reductions by Grouping

The groups utilize identical rows of longitudinal reinforcement located at the top and bottom of each beam. All four groups met ACI 3-08 code provisions and did not require diagonal reinforcement based on the length to height ratios (l_n/h). 300 North La Salle's design is controlled by wind loads therefore the shear strength of the concrete can resist the shear load. Under seismic provisions in chapter 21 of ACI 3-08, concrete shear strength, V_c , must be assumed to equal zero. This is to account for full cracking of the concrete during cyclic seismic loading. If the concrete fails completely, the steel must be able to carry the ultimate shear load without failing.

An important trait of coupling beams is that they should fail in flexure before failing in shear. During flexural failure the beam will remain in place with sagging, whereas during shear failure the beams would break from the piers and potentially collapse down leading to extensive damage and threat to human life. In keeping with good design practice, the beams were designed so that they will fail in flexure before shear. This was done by applying a 1.25 multiplier to the nominal moment that the flexural reinforcement provides, and then designing the nominal shear for this increased moment, M_{pr} . Theoretically this increased shear cannot be reached before the beam fails in flexure.

Worst case loading led to the following reinforcement designs. Group A has (3) #10 longitudinal bars in one row, top and bottom, with #4 stirrups spaced at 9". Group B has (8) #11 bars in a row of 5 and a row of 3, top and bottom, with #4 stirrups spaced at 9". Group C has (4) #10 bars in one row, top and bottom, with #4 stirrups spaced at 9". Group D has (12) #10 bars in two rows of 6, top and bottom, with #4 stirrups spaced at 9".

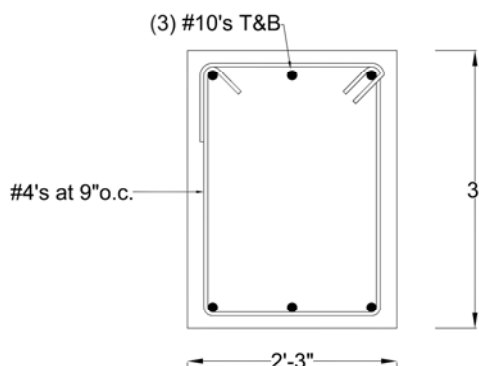

Fig. 33: Group A Coupling Beam Reinforcement

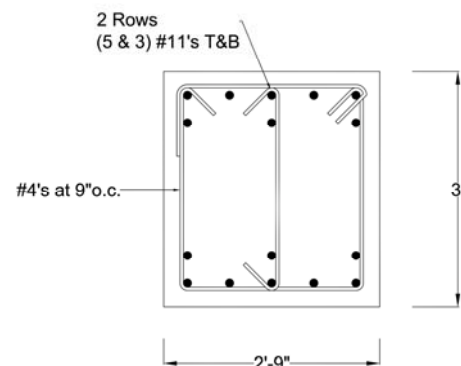

Fig. 34: Group B Coupling Beam Reinforcement

Lower Level 1 through Level 7 include deeper beams ranging from 60" – 132" compared to the 36" depths of the beams in Groups A-D. The varying depths required that these beams were analyzed individually and could not be grouped to effectively reduce the max moment. After initial analysis to find the area of steel, A_s , required to carry the max moment, it was found that the minimum A_s from ACI 3-08 21.5.2.1, equal to $200 \cdot b_w \cdot d / f_y$ controlled the design. Since these beams depths are greater than 36" they require skin reinforcement denoted as "Reinf 'C'" in Figures 35 & 36. The minimum skin reinforcement required on both vertical faces is #4 bars spaced at 10". The code provides that spacing is more important than size for skin reinforcement, therefore bar sizes #3-#5 are permitted to be used.

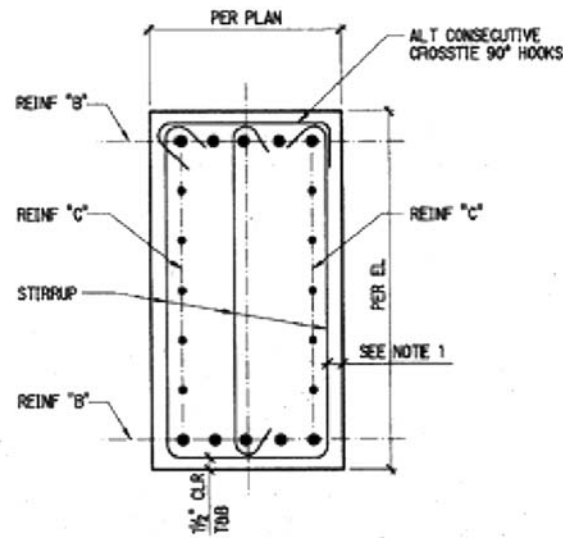

Fig. 35: Variable Coupling Beam per Plan: Lower Level 1 – Level 9

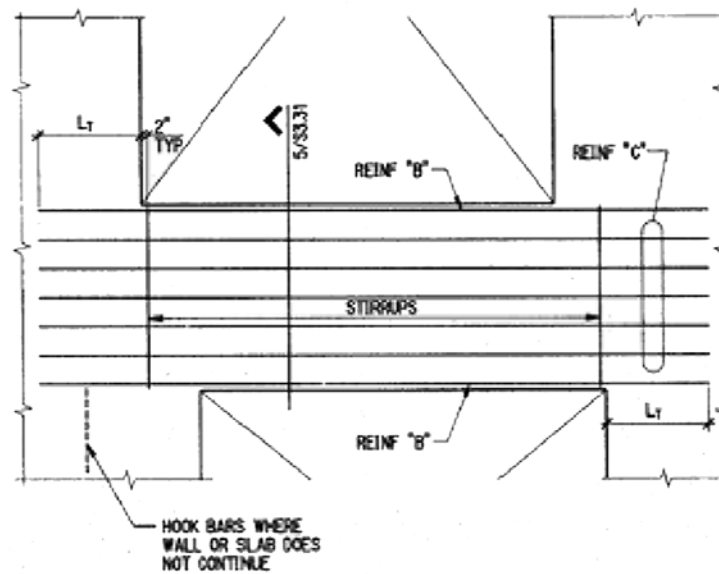

Fig. 36: Coupling Beam Elevation

Pier Reinforcement Design

Shear design for the walls consisted of examining each individual piece of the I-shaped piers under their worst case loadings. Each flange and web was labeled as an individual pier in ETABS, and $1.2D + 1.6L \pm 1.6W$ was applied in both the East-West and North-South direction. The reinforcement was then compared at Lower Level 1, Level 12, and Level 47, Table 9. These are a sampling within each different grouping of wall thicknesses and concrete strengths. The shear strength of the concrete ϕV_c was sufficient to carry the ultimate shear loads V_u on every level.

Wind Load in the North-South Direction							
Pier	Story	V_u (kips)	Width (in)	Length (in)	Height (in)	f'_c	ϕV_c
PIER 4	L47	782	24	477	156	6	12273
	L12	3184	27	477	156	8	11115
	LL1	3924	27	477	222	10	10740
PIER 5	L47	1059	24	477	156	6	12273
	L12	3189	24	477	156	8	13309
	LL1	3564	24	477	222	10	11247
PIER 6	L47	708	24	477	156	6	12274
	L12	2875	27	477	156	8	9954
	LL1	3593	27	477	222	10	10173

Table 9: Shear Strength of Webs at Piers 4-6

Therefore the walls only required minimum vertical and horizontal reinforcement from ACI 318-08 Chapter 11 and 14. By good design practice the minimum vertical reinforcement ratio used was 0.0025, as opposed to the 0.0012 permitted in chapter 14. Webs 4-6 required two rows of #5 bars spaced at 12" o.c. vertical reinforcement, and two rows of #5 bars spaced at 8" horizontal reinforcement throughout their height.

Shear Reinforcement (in^2)				
Pier	Vertical Shear Reinforcement		Horizontal Shear Reinforcement	
	As req'd $\rho = .0025$	As: # 5 @ 12"o.c.	As req'd $\rho = .0025$	As: # 5 @ 8"o.c.
PIER 4	14.77	24.18	7.49	11.78
	16.62	24.18	8.42	11.78
	15.45	24.18	14.99	16.75
PIER 5	14.77	24.18	7.49	11.78
	14.77	24.18	7.49	11.78
	13.74	24.18	13.32	16.75
PIER 6	14.77	24.18	7.49	11.78
	16.62	24.18	8.42	11.78
	15.45	24.18	14.99	16.75

Table 10: Shear Reinforcement of Webs at Piers 4-6

The six flanges all require two rows of #7 bars spaced at 12" as vertical reinforcement throughout their height. The flanges also required # 7 bars spaced at 12" as horizontal reinforcement as seen in Table 12.

Wind Load in the East-West Direction							
Pier	Story	Vu (kips)	Width (in)	Length (in)	Height (in)	f'c	ϕV_c
PIER B4 & C4	L47	135	27	108	156	6	2584
	L12	782	33	237	156	8	5266
	LL1	1034	36	237	222	10	4372
PIER B5 & C5	L47	491	27	279	156	6	6675
	L12	1557	33	279	156	8	7707
	LL1	1587	36	279	222	10	5821
PIER B6 & C6	L47	205	27	131.5	156	6	3146
	L12	702	33	240	156	8	4759
	LL1	1030	36	240	222	10	4342

Table 11: Shear Strength of Flanges at Piers 4-6

Shear Reinforcement (in ²)				
Pier	Vertical Shear Reinforcement		Horizontal Shear Reinforcement	
	As req'd $\rho = .0025$	As: # 7 @ 12" o.c.	As req'd $\rho = .0025$	As: # 7 @ 12" o.c.
PIER B4 & C4	7.29	9.6	7.49	14.4
	19.5525	22.8	8.42	14.4
	21.33	22.8	14.99	21.6
PIER B5 & C5	18.8325	27.6	7.49	14.4
	23.0175	27.6	7.49	14.4
	25.11	27.6	13.32	21.6
PIER B6 & C6	8.87625	12	7.49	14.4
	19.8	22.8	8.42	14.4
	21.6	22.8	14.99	21.6

Table 12: Shear Reinforcement of Flanges at Piers 4-6

In contrast to the shear reinforcement design, the flexural reinforcement design for the piers required that each I-shape was labeled as a whole in ETABS. ETABS moment and axial outputs on each pier were then used in collaboration with PCAColumn to design the flexural reinforcement. The controlling combination $0.9D \pm 1.6W$ applied in the North-South direction caused the need for tensile reinforcement in addition to the earlier designed vertical shear reinforcement from lower Level 1 – Level 11. When the combination was applied in the East-West direction additional tensile reinforcement was only required from lower Level 1 – Level 9.

The area of steel was initially calculated using the eqn. $A_s = (M/jd-P)/(\phi f_y)$. The results for Lower Level 1 and Level 36 can be seen below in Table 13.

Initial Area of Steel Requirements : Pier 4						
Story	Load	$\pm P_{Wind}$ (kips)	$\pm M_{Wind}$ (kip-in)	$0.9 P_{Dead}$ (kips)	ϕT_n (kips)	A_s (in ²)
L36	+NS	0	1169788	10002	-2633	no add.
	+EW	173	32003	10002	-4746	no add.
LL1	+NS	0	11209324	26271	9551	177
	+EW	25188.05	1008627	26271	4779	88

Table 13: Flexural Reinforcement of Piers 4-6

For comparison Pier 4 at Lower Level 1 and Level 36 was analyzed. Lower Level 1 required 177 in² of steel in each flange to carry the flexural stress from the North-South wind loads. The required steel was provided with (114) # 11 bars in three rows of approximately 38 bars, Figure 37. These bars can be spaced at 6" o.c. and provide a reinforcement ratio of 2% within each flange. Lower Level 1 required 89 in² of steel to carry the flexural stress from East-West wind loads. The (114) #11 bars that had previously been determined from the N-S load case provide a sufficient area of steel. After determining the A_s required, the piers were input into PCAColumn and their strengths were verified via PM interaction diagrams Figures 39& 40.

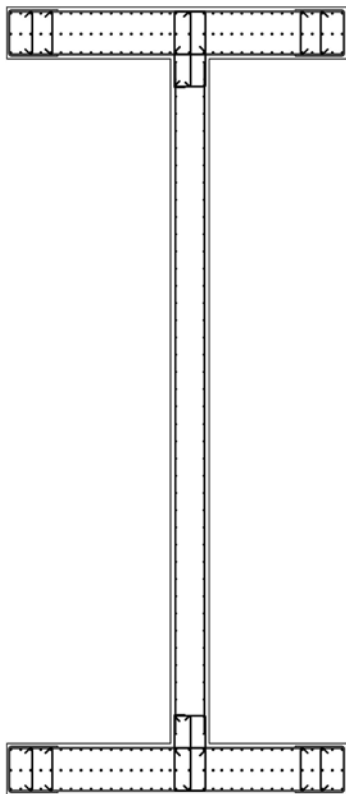

Fig. 37: Pier 4 @ Lower Level 1 with Boundary Elements

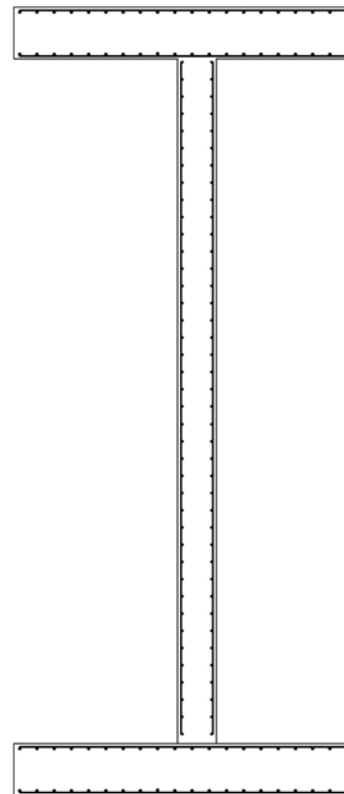

Fig. 38: Pier 4 @ Level 36 without Boundary Elements

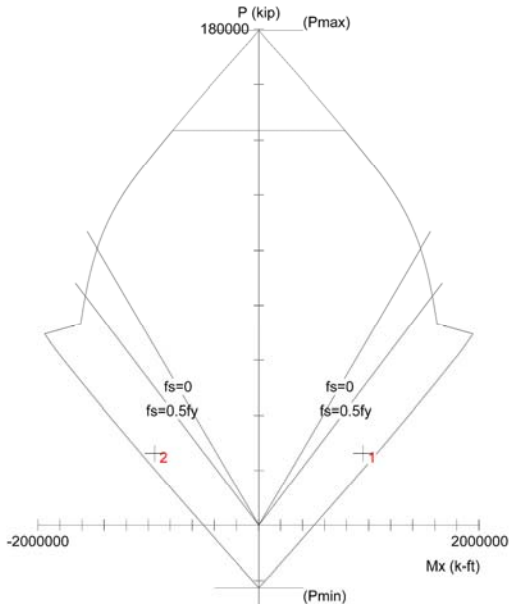

Fig. 40: Pier 4 @ Lower Level 1: P-M Interaction for E-W wind loading

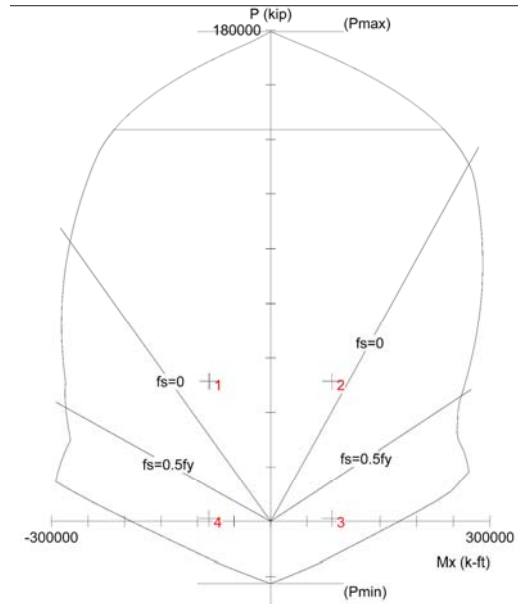

Fig. 39: Pier 4 @ Lower Level 1 : P-M Interaction for N-S wind loading

Analysis of Pier 4 at Level 36 under controlling load combinations resulted in no net tensile force within the pier. To confirm the hand calculation that the wall did not require additional flexural reinforcement, the pier was input into PCAColumn with it's previously designed vertical shear reinforcement, Figure 38. The controlling N-S and E-W moment and axial loads were input and found to be within the columns interaction diagram, Figures 41&42, confirming the hand calculation. The hand calculations can be found in Appendix D.

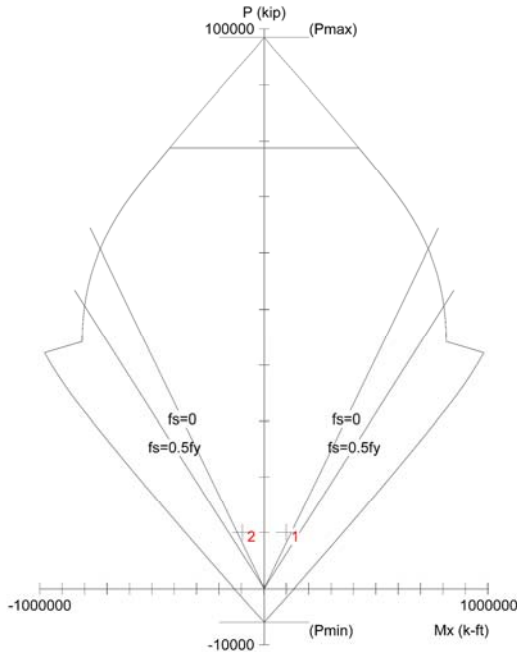

Fig. 41: Pier 4 @ Level 36 : P-M Interaction for N-S wind loading

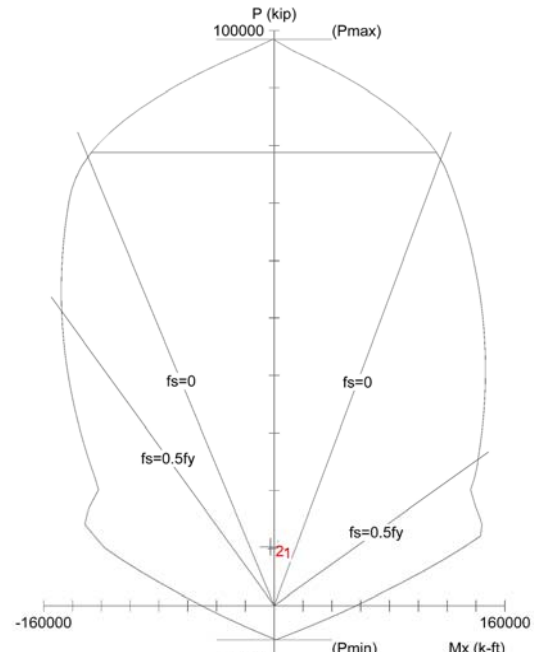

Fig. 42: Pier 4 @ Level 36 : P-M Interaction for E-W wind loading

Boundary Elements

Boundary elements are defined by ACI 318-08 Chapter 2 as a portion along a structural wall edge strengthened by longitudinal and transverse reinforcement. It also specifies that edges of openings within walls and diaphragms are provided with boundary elements as required by Chapter 21.

Boundary elements are used to prevent buckling of longitudinal reinforcement during seismic loading. The commentary in ACI 318-08 Chapter 21.9.6.5 states that cyclic load reversals could lead to buckling of longitudinal reinforcement even where demands on the boundary of the wall do not require special boundary elements. Since 300 North La Salle's controlling load cases are from wind and not seismic loads, the boundaries do not require special boundary elements, however minimum boundary elements are still designed as recommended by ACI 318-08.

The length of the boundary element is defined by section 21.9.6.4 as the larger of c or $0.1l_w$ and $c/2$ where c is the largest neutral axis depth. By this method the length of the boundary element at the flange edges, Figure 37, was only required to be 5.1". Using engineering judgment, this length was increased to $0.15 l_w$ in order to ensure development of the U-stirrups. The U-stirrups are used to "provide anchorage so that the reinforcement will be effective in resisting shear forces." Therefore the U-stirrups have the same size and vertical spacing as the transverse shear reinforcement previously defined for each floor. The ties are to ensure that the boundary element's longitudinal reinforcement does not buckle, and the minimum requirements are provided. These requirements are #5 ties with a horizontal spacing no greater than 14" and a vertical spacing no greater than 8".



Fig. 43: Typical Boundary Element Reinforcement at Flange Tips

The length of the boundary element at the intersection of the web and flanges must be at least 6.2" deep as calculated from aforementioned neutral axis equations. Again good engineering judgment was used and the boundary element was extended 12" into the web from the interior face of the flanges. The hoops are again necessary as defined by the transverse reinforcement per plan Level, and the #5 ties must remain spaced below the 14" maximum horizontal spacing and 8" maximum vertical spacing, as seen in Figure 44.

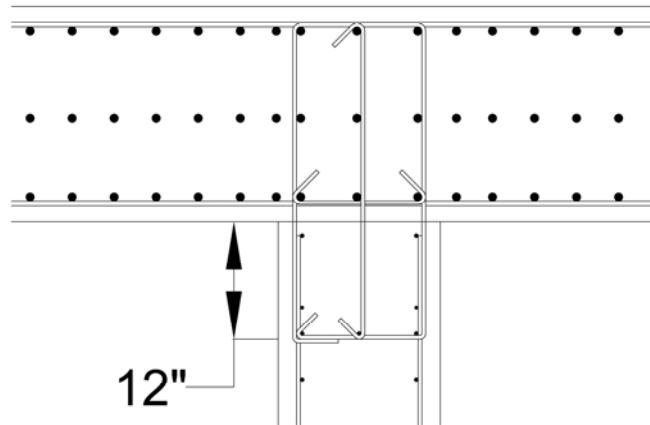

Fig. 44: Typical Boundary Element
Reinforcement at Web-Flange Connection

Foundations

The load combination $\pm 1.6W + 0.9 D$ was examined at the base of the structure. This combination can lead to uplift issues in the foundations. The overturning moment created by the wind load must be counteracted by the foundation via a couple moment of axial loadings. The axial loads are equal and opposite forces acting with gravity on one side and against gravity on the other. If the upward axial force cannot be counteracted by 0.9* the dead weight of the building, the foundations need to be designed to carry the excess upward force. Often times this is done using a mat foundation which can be costly in material and labor as well as schedule time. The most severe case was on Pier 4 when the wind load was in the E-W direction. The wind force up was 25,000 kips and was resisted by 26,000 kips of dead load. Since the dead load was still enough to counteract the upward wind force, the foundation in the new design will not experience any uplift problems, and the existing foundation should have sufficient strength to carry the new design loads.

Architectural Breadth

The new core design eliminated the need for walls 3 and 7, of the original design. However, these walls were shaft walls for the low and mid-rise elevator shafts. After investigating the current vertical circulation of the core it was deemed that the elevators would be allocated to serve different zones so that the goal of creating more open rentable square footage could be achieved. The mid-rise and low-rise elevators would now share two bays equally instead of the separate designations from the original plan as seen in Figures 45 & 36.

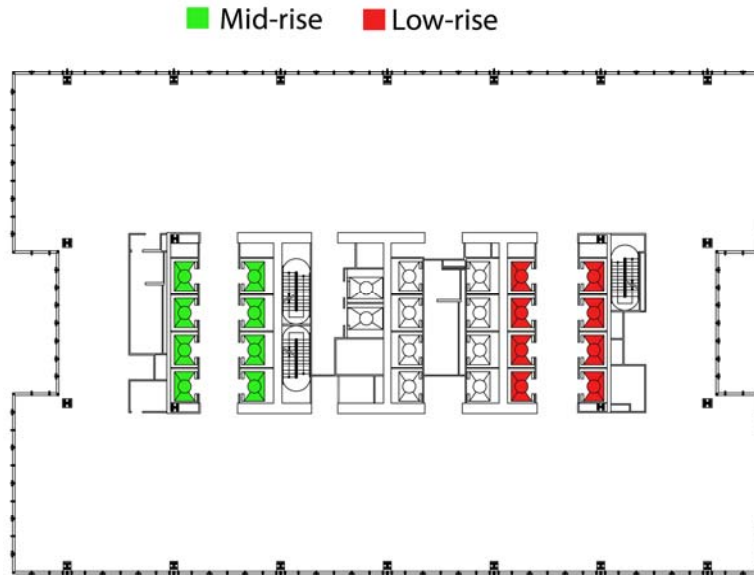

Fig. 45: Original Elevator Bay Designation –
Lower Level 1 – Level 27

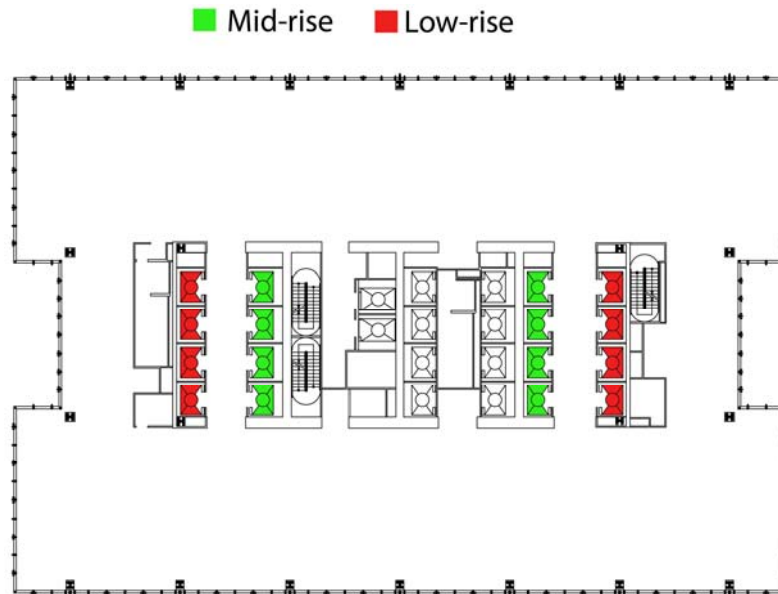

Fig. 46: Proposed Elevator Bay Designation
– Lower Level 1 – Level 27

Sharing the mid-rise and low-rise bays with four elevators servicing each sector per bay could present some potential problems. The primary entrance is on the eastern side of the building, and in the original configurations the occupants would enter and proceed west to either the high-rise, mid-rise, or low-rise bay depending on what sector their intended floor was located. By splitting the bays in the new design however, people headed for both the mid and low rise levels will be more likely to go to the closest bay instead of walking to the farthest bay which is also split in its service areas. The tendency of occupants to wait at the closer bay could lead to increased wait times at the elevators. To alleviate this potential problem, it is suggested that the elevators now be assigned certain floors within each service area, i.e. instead of having 8 “low-rise” elevators servicing Level 1- Level 27, there will be 4 elevators for Level 1-Level 14, and 4 elevators for Level 14-Level 27. This reassignment of elevators would also be done for the mid-rise levels.

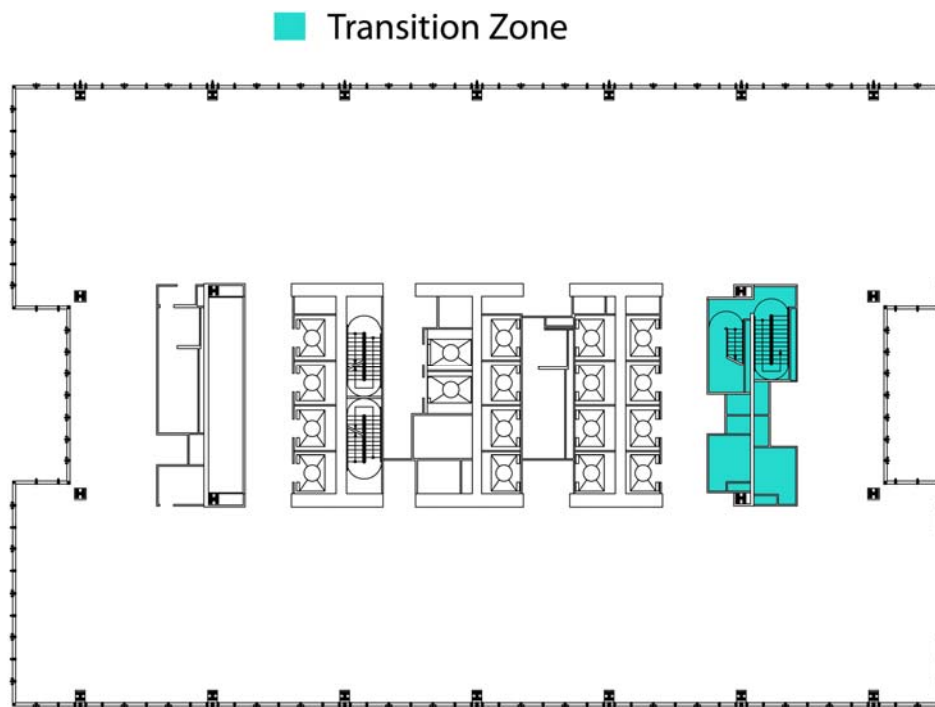

Fig. 47: Stairwell connection and HVAC
Transition area – Level 28

By reallocating the exterior 4 elevators on Walls 3 & 7 to the low rise levels, floor space can be gained when they drop out of service. In the original layout, the floors above the lower level elevators gained a confined closet or storage space between core walls 6&7. In the new design, this open space is moved to the exterior open floor and allows for more flexible usage of the space. Using Level 28 as a transition level, Figure 47, for the MEP ducts and pipes, as well as the stairwell, yields an additional 900sqft, Figure 48, of open floor space per level from Level

29-40. This provides a net gain of over 10,000sq.ft. This increase of square footage in the open plan could be beneficial to the owner, Hines, when marketing each floor plan to prospective tenants. 300 North La Salle does not have predesigned office plans, so that the tenants can design the space to their needs. In the original design, the clients would only have had the option to use the space above the low-rise elevators as a closet; this was because the concrete core walls prevented the MEP and storage rooms from transitioning over as they do in the new design. Hines can now offer the prospective tenants more freedom, and possibly charge a higher rate for the new open square footage.

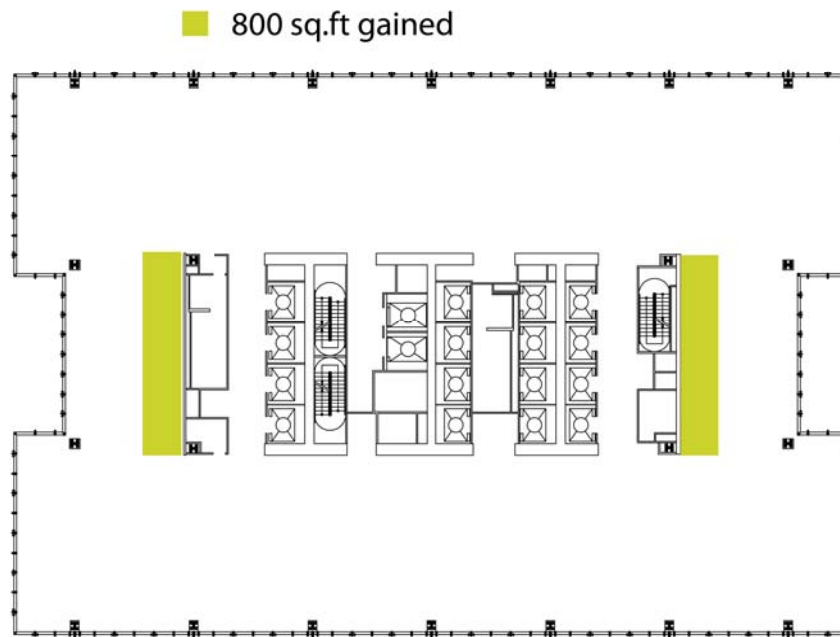

Fig. 48: Location of Open Floor Area
Gained by Redesign – Level 29 – Level 40

Due to the removal of the cast-in-place concrete shaft walls, new walls had to be designed to meet fire protection codes for elevator shafts. The US Gypsum Board Company provides these type wall configurations with varying fire ratings. The IBC requires that shaft walls are of equal fire rating to the floors they extend through, but need not have a fire rating greater than 2hrs. The US Gypsum shaft walls are a quick and easy way to effectively enclose the elevator shaft and provide the necessary 2-hr fire rating by code. The process encloses the shaft early during construction and then the walls are completed later with the interior partitions.

**Typical Shaft
Wall Assembly**

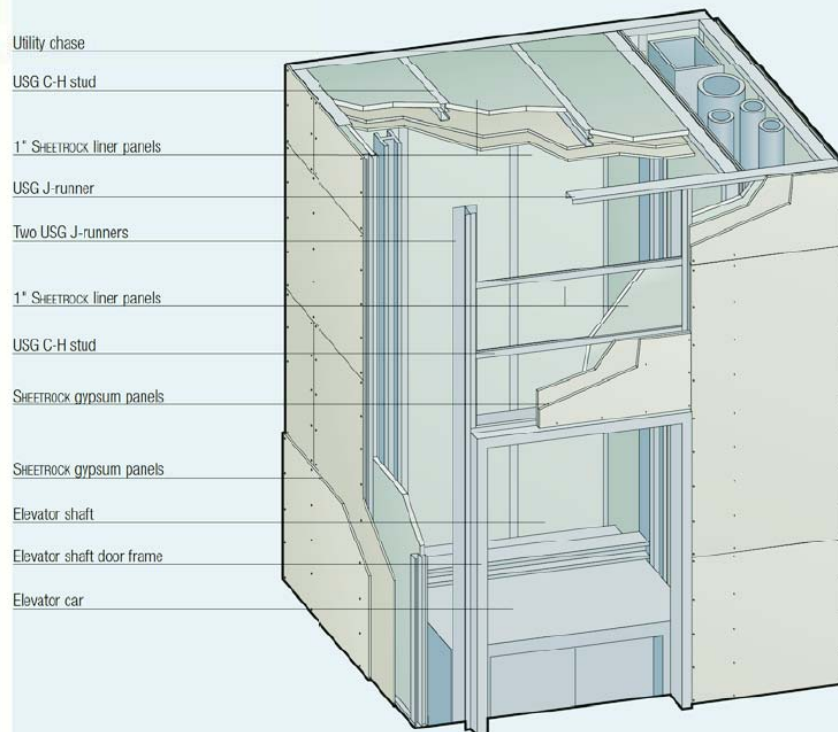

Fig. 49: Typical Gypsum Fire-rated Shaft Assembly
(Courtesy of USG.com)

The typical assembly is panelized with gypsum panels friction-fitted into C or H shapes in a progressive manner and has gypsum panels, gypsum fiber panels, or cement board applied to the face. The assembly is quick and easy because it deals with products and techniques familiar to drywall contractors. It also allows the entire system to be installed from one side allowing the shaft to remain free of scaffolding during construction.

The new steel columns are also enclosed by 2hr fire rated drywall as seen in Figures 45 – 48. Enclosing the columns within the 2-hr wall assembly provides several benefits. Aesthetically there is a solid wall without exposed structural steel, and by not exposing the structural steel, spray-on fireproofing is not required. Spray-on fireproofing is costly in material and labor costs and requires an additional allotment of time in the schedule. Enclosing the new columns in the wall assembly and with 2hr fire rated drywall can be done during the drywall stage of construction and will not add additional time to the construction schedule.

Acoustical Breadth

The removal of the concrete walls presented more issues than maintaining fire ratings through the shaft. The acoustic properties of the wall must also be evaluated to maintain proper sound reduction at the office levels. The elevator shaft contains an elevator machine room, and also connects the noisy lobby area to the private office floors. The low frequency machine noises and the lobby background noises need to be reduced so that the office workers are not disturbed. “Architectural Acoustics” by David Egan recommends that office area’s have a noise criteria range between NC-30 and NC-35 and an equivalent adjusted decibel level, dBA, range from 38 to 42. The elevator machine room and reception area emit sound decibel levels across a range of frequencies as shown in Table 14. It should be noted that while the most critical frequency for mechanical equipment rooms is 63 Hz where mechanical equipment emits high decibels of sound, this frequency was neglected during wall selection. This is because an elevator machine room does not have the same motors and equipment as the typical mechanical equipment room which was used to approximate its sound pressures.

Example Source	Sound Pressure Level (dB)								dBA
	63 Hz	125 Hz	250 Hz	500 Hz	1000 Hz	2000 Hz	4000 Hz	8000 Hz	
Mechanical Equipment Room	87	86	85	84	83	82	80	78	88
Reception and Lobby	60	66	72	77	74	68	60	50	78

Table 14: Background Noise Levels

The USG has several approved configurations to meet the required 2-hr fire rating. Each of these configurations provides a different level of sound reduction. Walls are rated by their Sound Transmission Class, STC, which is a single numerical value referring to their transmission loss performance. The STC rating is the dB transmission loss at 500 Hz for a given material or assembly of materials.

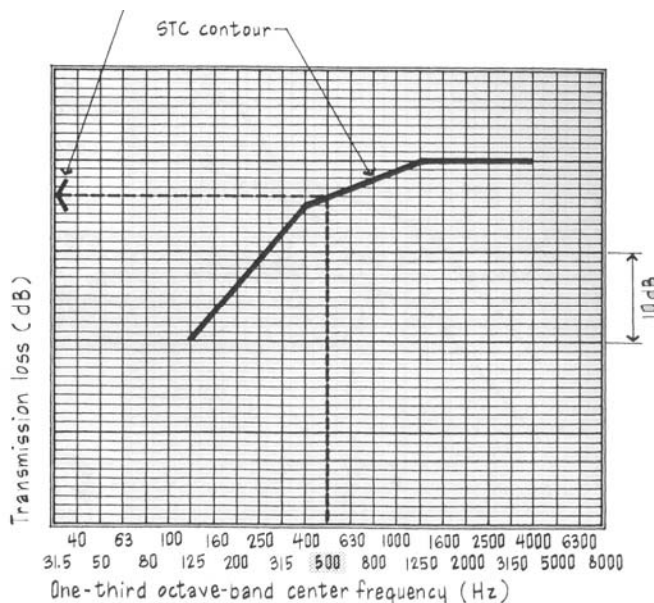

Fig. 50: Typical STC contour adjusted vertically by 500 Hz rating (Courtesy of M.D. Egan)

The Noise Criteria (NC) curves are a predetermined set of curves used to specify the acceptable levels of continuous background noise to achieve satisfactory sound isolation. Each curve is defined by its dB level for eight octave-band center frequencies ranging from 63 Hz to 8000 Hz (Egan). The NC rating for a noise situation typically refers to the lowest NC curve that is not exceeded at any octave-band sound pressure level. The critical noise source at the majority of frequencies was the mechanical equipment room, however since the lowest frequency had been ignored for this source, the 60 dB pressure level from the reception and lobby controlled at 63 Hz. The highest and lowest STC rated USG wall assemblies were analyzed and compared under the NC requirements.

1-Hour Fire-rated Construction		Non-loadbearing		Acoustical Performance		Reference	
Construction Detail	Description	Test Number	STC	Test Number	ARL	Index	
	<ul style="list-style-type: none"> 5/8" SHEETROCK FIRECODE Core gypsum panels, joints finished 2-1/2" USG C-H Studs 25 gauge 24" o.c. 1" SHEETROCK gypsum liner panels 	UL Des U415, System A or U469	39	USG-040901 Based on 4" C-H studs 25 gauge	SA926	1	
2-Hour Fire-rated Construction							
	<ul style="list-style-type: none"> 1/2" SHEETROCK FIRECODE C Core gypsum panels, face layer joints finished 2-1/2" USG C-H Studs 25 gauge 24" o.c. 1" SHEETROCK gypsum liner panels 	UL Des U415, System B or U438	38 43 48 50	USG-040917 USG-040912 RAL-0T-04-022 RAL-0T-04-019 Based on 4" C-H studs 25 gauge with 3" mineral fiber insulation	SA926	2	
	<ul style="list-style-type: none"> 3/4" SHEETROCK ULTRACODE Core gypsum panels, joints finished 4" USG C-H studs 25 gauge 24" o.c. 3" THERMAFIBER SAFB 1" SHEETROCK gypsum liner panels 	UL Des U415, System C	51	RAL-0T-04-020 Based on 4" C-H studs with 3" THERMAFIBER SAFB insulation	SA926	3	
	<ul style="list-style-type: none"> 1/2" DUROCK cement board, joints finished 5/8" SHEETROCK FIRECODE Core gypsum panels 2-1/2" USG C-H studs 20 gauge 24" o.c. 1-1/2" THERMAFIBER SAFB 1" SHEETROCK gypsum liner panels DUROCK cement board screw attached and laminated to gypsum panel with 4 vertical strip ceramic tile mastic centered between studs 	UL Des U415, System D			SA926	4	
	<ul style="list-style-type: none"> 1/2" SHEETROCK FIRECODE C Core gypsum panels 2-1/2" USG C-H Studs 25 gauge 24" o.c. 1" SHEETROCK gypsum liner panels joints finished both sides 	UL Des U415, System E or U467	44	USG-040911 Based on 4" C-H studs 25 gauge	SA926	5	

Fig. 51: Fire-ratings and Acoustic properties of Shaft Assemblies (Courtesy of USG.com)

The 2-hr Fire-rated UL Des U415, System E, STC 44, reduced the sound pressures levels of both sources to those seen in Table 15.

Example Source	Sound Pressure Level (dB) for STC 44							
	63 Hz	125 Hz	250 Hz	500 Hz	1000 Hz	2000 Hz	4000 Hz	8000 Hz
Mechanical Equipment Room	87	86	85	84	83	82	80	78
Reception and Lobby	60	66	72	77	74	68	60	50

Table 15: Background Noise Levels Transmitted through System E

When these dB levels were graphed on the NC curve chart, it was determined that System C provides an NC rating of 40. The NC-40 rating is above the suggested, NC-35 and therefore will not be an acceptable assembly based on acoustic requirements.

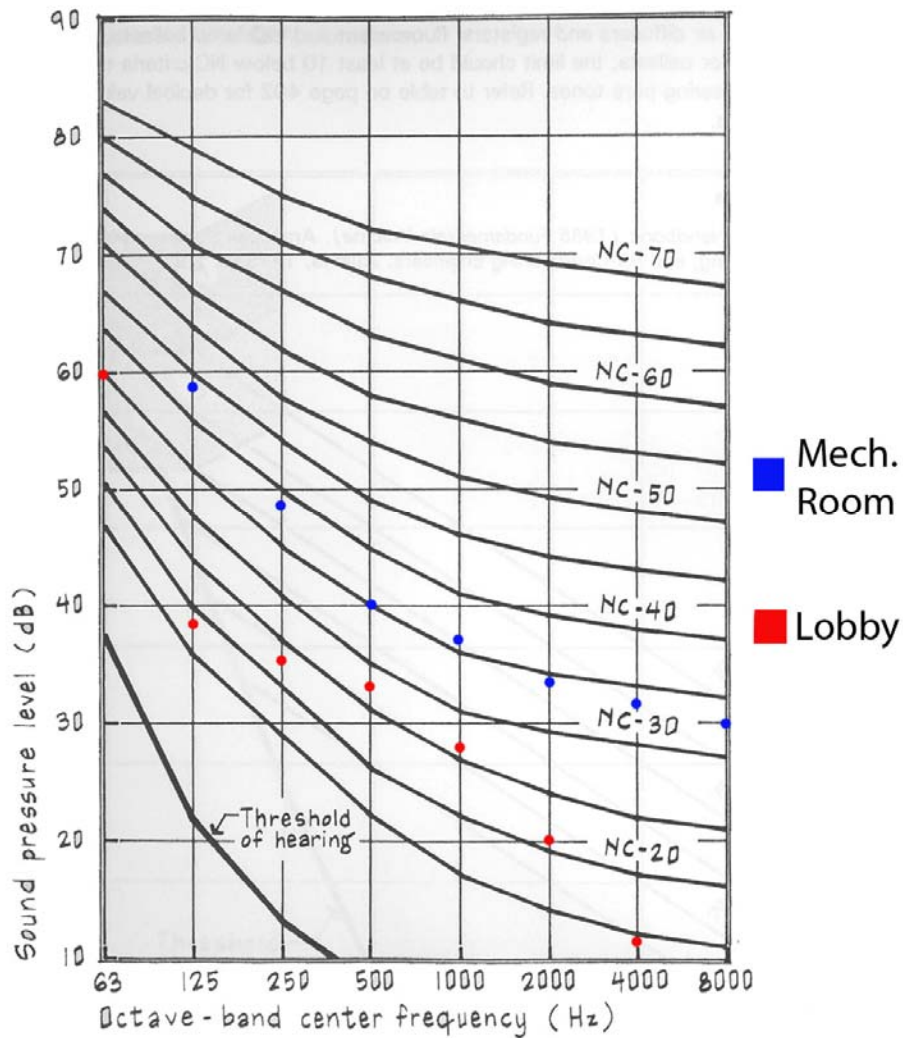

Fig. 52: Plot of Background Noise Levels to determine NC-Rating for Assembly E

The 2-hr Fire-rated UL Des U415, System C, STC 51, reduced the sound pressures levels of both sources to those seen in Table 16.

Example Source	Sound Pressure Level (dB) for STC 51							
	63 Hz	125 Hz	250 Hz	500 Hz	1000 Hz	2000 Hz	4000 Hz	8000 Hz
Mechanical Equipment Room	87	51	41	33	29	27	25	23
Reception and Lobby	60	31	28	26	20	13	5	-5

Table 16: Background Noise Levels Transmitted through System C

When these dB levels were graphed on the NC curve chart, it was determined that System C provides an NC rating of 35. The NC-35 rating was the target limit, and the wall will be adequate to isolate the offices from the noise in the shaft.

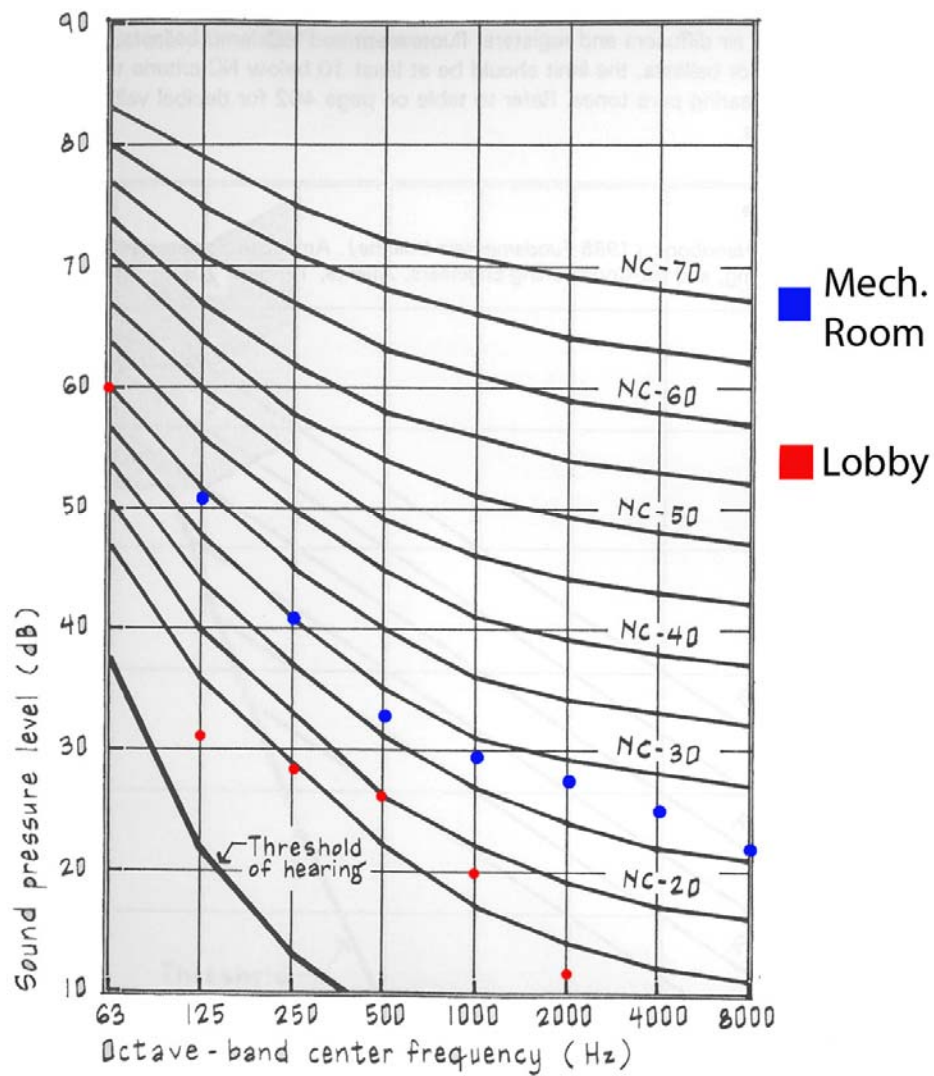

Fig. 53: Plot of Background Noise Levels to determine NC-Rating for Assembly C

The STC ratings for wall assemblies are often determined through controlled laboratory experiments and may not accurately reflect actual performance. To ensure the walls perform close to their specifications it is recommended that some additional steps are taken during the construction process. These steps are provided in the following checklist.(Egan)

1. Seal all cracks, joints and penetrations with continuous beads of non-hardening caulking.
2. Stagger electrical outlets and switches so they will be offset by at least one stud, and seal outlet box openings.
3. Isolate plumbing from framing elements and gypsum board layers because they can easily transmit noise of flowing water. Use resilient pipe supports and ensure airtight seals on all penetrations.
4. Stagger gypsum layers and attach layers with visco-elastic adhesives when possible.

The important thing is to keep the walls as flexible as possible, and to use air tight seals on all openings. When a wall is flexible its vibration can help reduce the transmission of sound through it. Sound will follow the path of least resistance, and any opening that allows air to pass will reduce the walls ability to reduce sound transmission.

Conclusion

The re-design of the 300 North La Salle was successful in reducing the core length from 120' to 80', and could provide up to 10,000 additional sq.ft. of open office space. The core's maximum drift of 22" and peak acceleration of 27 milli-g's are within their respective recommended limits. Another positive aspect of the design is its symmetry between each I-shape, and about its N-S and E-W axes. The symmetry of the designed I-shapes resulted in close relative stiffness and simplified reinforcement detailing. It also increased the flexibility of the floor layouts. The design also had no uplift force on the foundation, allowing for the original designed foundation to be maintained.

US Gypsum's shaft wall assembly ULDES U415 System C provided adequate 2-hr fire-rating to meet code, while also successfully limiting the background noise from mechanical rooms and the lobby from disturbing the office spaces around the elevator shaft.

Based on the newly designed lateral system's success in adhering to serviceability criteria, while meeting strength requirements, increasing usable floor area, and avoiding negative impacts on the private office space, it is the recommendation of the designer that the final design is a viable option for a high-rise building in Chicago, Illinois.

Works Cited

Griffis, Lawrence G. "Serviceability Limit States Under Wind Load." *Engineering Journal - AISC* First Quarter (1993): 1-16. Print.

Egan, M. David. *Architectural Acoustics*. Ft. Lauderdale, FL: J. Ross Pub., 2007. Print.

Building Code Requirements for Structural Concrete (ACI 318-08) and Commentary: an ACI Standard. Farmington Hills, MI.: American Concrete Institute, 2008. Print.

Steel Construction Manual 13th edition. Chicago, Illinois: American Institute of Steel Construction, 2005. Print.

Appendix A – Gravity Columns

Preliminary Column Sizing

Level	Trib. Area	LLr	Live Load (lbs)	Dead Load (lbs)	Total Load (kips)	KL
42	23223	0	1189012	1683891	2873	12
41	24319	0	1245155	1763402	3009	14
40	25416	0	1301298	1842913	3144	14
39	26513	0	1357442	1922424	3280	13
38	27609	0	1413585	2001934	3416	13
37	28706	0	1469728	2081445	3551	13
36	29802	0	1525872	2160956	3687	13
35	30899	0	1582015	2240467	3822	13
34	31995	0	1638158	2319978	3958	13
33	33092	0	1694302	2399489	4094	13
32	34188	0	1750445	2479000	4229	13
31	35285	0	1806588	2558510	4365	13
30	36381	0	1862732	2638021	4501	13
29	37478	0	1918875	2717532	4636	13
28	38575	0	1975019	2797043	4772	13
27	39671	0	2031162	2876554	4908	13
26	40768	0	2087305	2956065	5043	13
25	41864	0	2143449	3035575	5179	13
24	42961	0	2199592	3115086	5315	13
23	44057	0	2255735	3194597	5450	13
22	45154	0	2311879	3274108	5586	13
21	46250	0	2368022	3353619	5722	13
20	47347	0	2424165	3433130	5857	13
19	48444	0	2480309	3512640	5993	13
18	49540	0	2536452	3592151	6129	13
17	50637	0	2592596	3671662	6264	13
16	51733	0	2648739	3751173	6400	13
15	52830	0	2704882	3830684	6536	13
14	53926	0	2761026	3910195	6671	13
13	55023	0	2817169	3989705	6807	13
12	56119	0	2873312	4069216	6943	13
11	57216	0	2929456	4148727	7078	13
10	58312	0	2985599	4228238	7214	13
9	59409	0	3041742	4307749	7349	13
7	61602	0	3154029	4466771	7621	18
6	62699	0	3210172	4546281	7756	21
5	63795	0	3266316	4625792	7892	13
4	64892	0	3322459	4705303	8028	15
2	67085	0	3434746	4864325	8299	18
1	68181	0	3490889	4943836	8435	19
0	69278	0	3547033	5023346	8570	19

		W 14 x												
Level	730	665	605	550	500	455	426	398	370	342	311	283	257	233
42	9030	8220	7440	6760	6120	5570	5190	4850	4510	4180	3780	3430	3110	2810
41	8810	8010	7250	6580	5950	5420	5040	4710	4380	4050	3660	3330	3010	2720
40	8810	8010	7250	6580	5950	5420	5040	4710	4380	4050	3660	3330	3010	2720
39	8920	8110	7350	6670	6040	5500	5120	4780	4450	4120	3720	3380	3060	2770
38	8920	8110	7350	6670	6040	5500	5120	4780	4450	4120	3720	3380	3060	2770
37	8920	8110	7350	6670	6040	5500	5120	4780	4450	4120	3720	3380	3060	2770
36	8920	8110	7350	6670	6040	5500	5120	4780	4450	4120	3720	3380	3060	2770
35	8920	8110	7350	6670	6040	5500	5120	4780	4450	4120	3720	3380	3060	2770
34	8920	8110	7350	6670	6040	5500	5120	4780	4450	4120	3720	3380	3060	2770
33	8920	8110	7350	6670	6040	5500	5120	4780	4450	4120	3720	3380	3060	2770
32	8920	8110	7350	6670	6040	5500	5120	4780	4450	4120	3720	3380	3060	2770
31	8920	8110	7350	6670	6040	5500	5120	4780	4450	4120	3720	3380	3060	2770
30	8920	8110	7350	6670	6040	5500	5120	4780	4450	4120	3720	3380	3060	2770
29	8920	8110	7350	6670	6040	5500	5120	4780	4450	4120	3720	3380	3060	2770
28	8920	8110	7350	6670	6040	5500	5120	4780	4450	4120	3720	3380	3060	2770
27	8920	8110	7350	6670	6040	5500	5120	4780	4450	4120	3720	3380	3060	2770
26	8920	8110	7350	6670	6040	5500	5120	4780	4450	4120	3720	3380	3060	2770
25	8920	8110	7350	6670	6040	5500	5120	4780	4450	4120	3720	3380	3060	2770
24	8920	8110	7350	6670	6040	5500	5120	4780	4450	4120	3720	3380	3060	2770
23	8920	8110	7350	6670	6040	5500	5120	4780	4450	4120	3720	3380	3060	2770
22	8920	8110	7350	6670	6040	5500	5120	4780	4450	4120	3720	3380	3060	2770
21	8920	8110	7350	6670	6040	5500	5120	4780	4450	4120	3720	3380	3060	2770
20	8920	8110	7350	6670	6040	5500	5120	4780	4450	4120	3720	3380	3060	2770
19	8920	8110	7350	6670	6040	5500	5120	4780	4450	4120	3720	3380	3060	2770
18	8920	8110	7350	6670	6040	5500	5120	4780	4450	4120	3720	3380	3060	2770
17	8920	8110	7350	6670	6040	5500	5120	4780	4450	4120	3720	3380	3060	2770
16	8920	8110	7350	6670	6040	5500	5120	4780	4450	4120	3720	3380	3060	2770
15	8920	8110	7350	6670	6040	5500	5120	4780	4450	4120	3720	3380	3060	2770
14	8920	8110	7350	6670	6040	5500	5120	4780	4450	4120	3720	3380	3060	2770
13	8920	8110	7350	6670	6040	5500	5120	4780	4450	4120	3720	3380	3060	2770
12	8920	8110	7350	6670	6040	5500	5120	4780	4450	4120	3720	3380	3060	2770
11	8920	8110	7350	6670	6040	5500	5120	4780	4450	4120	3720	3380	3060	2770
10	8920	8110	7350	6670	6040	5500	5120	4780	4450	4120	3720	3380	3060	2770
9	8920	8110	7350	6670	6040	5500	5120	4780	4450	4120	3720	3380	3060	2770
7	8290	7520	6790	6160	5560	5050	4690	4380	4070	3760	3390	3080	2780	2770
6	7830	7095												
5	8920	8110	7350	6670	6040	5500	5120	4780	4450	4120	3720	3380	3060	2770
4	8690	7890	7350	6670	6040	5500	5120	4780	4450	4120	3720	3380	3060	2770
2	8920	8110	7350	6670	6040	5500	5120	4780	4450	4120	3720	3380	3060	2770
1	8190	8110	7350	6670	6040	5500	5120	4780	4450	4120	3720	3380	3060	2770
0	8190	8110	7350	6670	6040	5500	5120	4780	4450	4120	3720	3380	3060	2770

Appendix B

Acceleration Calculations & Equations

Original Model Flexible		4th Iteration Flexible	
H	237.4392 m	H	237.4392 m
B	49.69583837 m	B	49.69583837 m
TD	7.85 sec	TD	7.7 sec
TL	5.96 sec	TL	7.6 sec
T θ	5.7 sec	T θ	5.99 sec
M	96112140.87 kg	M	96112140.87 kg
Mmi	429.1489458	Mmi	429.1489458
N	0.127388535 1/sec	N	0.12987013 1/sec
NL	0.167785235 1/sec	NL	0.131578947 1/sec
N θ	0.175438596 1/sec	N θ	0.166944908 1/sec
KD	20524728.44 N/m	KD	21332182.12 N/m
KL	35606084.13 N/m	KL	21897248.58 N/m
K θ	16706099813 N/m	K θ	15127638522 N/m
ζ	0.015 %	ζ	0.015 %
Plan Area	26583.375 ft ²	Plan Area	26583.375 ft ²
UH	32.0851387 m/s	UH	32.0851387 m/s
V	49.33529412 mph	V	49.33529412 mph
CD	7.604201477	CD	7.604201477
CL	0.757696633	CL	0.757696633
C θ	153.6595026	C θ	153.6595026
N θ *B/UH	0.271732288	N θ *B/UH	0.258576634
AD	0.030631917	AD	0.030197693
AL	0.038264043	AL	0.055637108
A θ	0.001217575	A θ	0.001264373
B/ $\sqrt{2}$ x A θ	0.042785911	B/ $\sqrt{2}$ x A θ	0.044430406
AD (Milli-g)	3.12252E-06	AD (Milli-g)	3.07826E-06
AL (Milli-g)	3.90051E-06	AL (Milli-g)	5.67147E-06
B/ $\sqrt{2}$ x A θ (Milli- g)	4.36146E-06	B/ $\sqrt{2}$ x A θ (Milli- g)	4.52909E-06
AR	6.63223E-06 24.87085871	AR	7.88377E-06 29.5641554

Original Model Rigid	
H	237.4392 m
B	49.69583837 m
TD	7.06 sec
TL	5.78 sec
Tθ	5.47 sec
M	96112140.87 kg
Mmi	429.1489458
N	0.141643059 1/sec
NL	0.173010381 1/sec
Nθ	0.182815356 1/sec
KD	25375074.8 N/m
KL	37858295.46 N/m
Kθ	18140536645 N/m
ζ	0.015 %
Plan Area	26583.375 ft^2
UH	32.0851387 m/s
V	49.33529412 mph
CD	7.604201477
CL	0.757696633
Cθ	153.6595026
Nθ*B/UH	0.28315796
AD	0.028319534
AL	0.03649896
Aθ	0.001180052
B/√2 x Aθ	0.041467348
AD (Milli-g)	2.8868E-06
AL (Milli-g)	3.72059E-06
B/√2 x Aθ (Milli- g)	4.22705E-06
AR	6.32806E-06 23.73022377

4th Iteration Rigid	
H	237.4392 m
B	49.69583837 m
TD	7.38 sec
TL	7.12 sec
Tθ	5.95 sec
M	96112140.87 kg
Mmi	429.1489458
N	0.135501355 1/sec
NL	0.140449438 1/sec
Nθ	0.168067227 1/sec
KD	23222234.67 N/m
KL	24949206.97 N/m
Kθ	15331719029 N/m
ζ	0.015 %
Plan Area	26583.375 ft^2
UH	32.0851387 m/s
V	49.33529412 mph
CD	7.604201477
CL	0.757696633
Cθ	153.6595026
Nθ*B/UH	0.260314964
AD	0.029263909
AL	0.050318861
Aθ	0.001257951
B/√2 x Aθ	0.044204735
AD (Milli-g)	2.98307E-06
AL (Milli-g)	5.12934E-06
B/√2 x Aθ (Milli- g)	4.50609E-06
AR	7.45075E-06 27.94032061

4th Iteration Semi-Rigid	
H	237.4392 m
B	49.69583837 m
TD	7.4 sec
TL	7.2 sec
Tθ	5.95 sec
M	96112140.87 kg
Mmi	429.1489458
N	0.135135135 1/sec
NL	0.138888889 1/sec
Nθ	0.168067227 1/sec
KD	23096878.71 N/m
KL	24397860.3 N/m
Kθ	15331719029 N/m
ζ	0.015 %
Plan Area	26583.375 ft ²
UH	32.0851387 m/s
V	49.33529412 mph
CD	7.604201477
CL	0.757696633
Cθ	153.6595026
Nθ*B/UH	0.260314964
AD	0.029322575
AL	0.051192184
Aθ	0.001257951
B/√2 x Aθ	0.044204735
AD (Milli-g)	2.98905E-06
AL (Milli-g)	5.21837E-06
B/√2 x Aθ (Milli-g)	4.50609E-06
AR	7.51469E-06 28.18009955

Along-wind:

$$A_D(Z) = C_D(Z) \frac{U_H^{2.74}}{K_D^{0.37} \times \zeta^{0.5} \times M_D^{0.63}} \quad (1)$$

Across-wind:

$$A_L(Z) = C_L(Z) \frac{U_H^{2.54}}{K_L^{0.77} \times \zeta^{0.5} \times M_L^{0.23}} \quad (2)$$

Torsional:

$$A_\theta(Z) = C_\theta(Z) \frac{U_H^{1.88}}{K_\theta^{0.06} \times \zeta^{0.5} \times M_\theta^{1.06}} \frac{N_\theta B}{U_H} \leq 0.25 \quad (3a)$$

$$A_\theta(Z) = C_\theta(Z) \frac{U_H^{2.76}}{K_\theta^{0.38} \times \zeta^{0.5} \times M_\theta^{0.62}} \frac{N_\theta B}{U_H} > 0.25 \quad (3b)$$

The proportionality constants $C_D(Z)$, $C_L(Z)$, and $C_\theta(Z)$ are defined as follows:

$$C_D(Z) = 0.0116 \times B^{0.26} \times Z$$

$$C_L(Z) = 0.0263 \times B^{-0.54} \times Z$$

$$C_\theta(Z) = 0.00341 \times B^{2.12} \times Z, \frac{N_\theta B}{U_H} \leq 0.25$$

$$C_\theta(Z) = 0.00510 \times B^{1.24} \times Z, \frac{N_\theta B}{U_H} > 0.25$$

The definition of terms in the above expressions are listed below:

$$A_D(Z), A_L(Z), A_\theta(Z) = \text{along-wind, across-wind, and torsional RMS acceleration at height } Z \text{ (meters/sec}^2\text{, radians/sec}^2\text{)}$$

U_H = mean hourly wind speed at the top of the building (meters/sec.)

H = building height (meters)

B = plan dimension of square building (meters)

M = generalized mass of the building (kilogram)

$$= \sum_{i=1}^n m_i \phi_i^2 \quad m_i \text{ is mass of floor } i \text{ and } \phi_i \text{ is modal}$$

coordinate at floor i , normalized so that $\phi = 1$ at $(Z) = H$

N = frequency (hertz)

K = generalized stiffness (newton/meters)

$$= (2\pi N)^2 \times M$$

ζ = damping ratio

For rectangular buildings, B may be taken as the square root of the plan area. The resultant RMS acceleration at the corner of the building, A_R , is calculated as follows:

$$A_R = (A_D^2 + A_L^2 + (B/\sqrt{2} \times A_\theta)^2)^{0.5} \quad (4)$$

Appendix C Coupling Beam : Shear and Flexure

Design of Coupling Beam Reinforcement:

Level 57: Beam 91

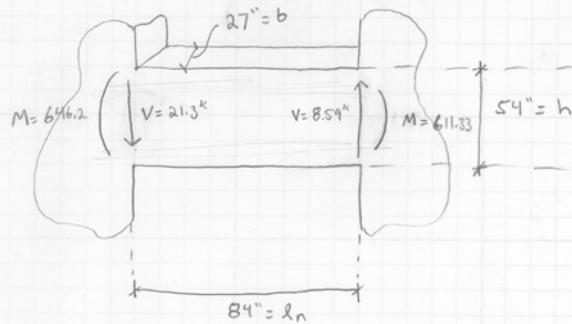

Given: $f'_c = 6,000$ psi
 $f_y = 60,000$ psi

ACI 21.9.7.1 $l_n/h = 84''/54'' = 1.56 < 4$

21.9.7.2 $l_n/h < 2$ \therefore check $V_u \leq 4\lambda\sqrt{f'_c} A_{cw}$

$A_{cw} = b \cdot h$ $\lambda = 1 \Rightarrow 4(1)\sqrt{(6^k)}(27'')(54'') = 14,285^k \gg V_u$

\therefore

ACI 21.9.7.3 permits use of ACI 21.5.2 - 21.5.4

21.5.2.1: min reinforcement = min $\left| \begin{array}{l} \frac{3\sqrt{f'_c} b_w d}{f_y} = \text{Eqn 10-5} \\ 200b_w d / f_y \end{array} \right.$

$\frac{3\sqrt{f'_c}}{f_y} = \frac{3(\sqrt{6,000})}{60,000} = 0.00387 \leftarrow \text{controls}$

$\frac{200}{60,000} = 0.00333$

Assume #10

$A_{s, \min} = \frac{3\sqrt{6,000}}{60,000} (27'')(54'' - 1.5'' - \frac{5}{8}'') = 5.425 \text{ in}^2 < \rho = 0.025 (A_{cw}) = 32.4 \text{ in}^2$

of 10's = $\frac{5.43 \text{ in}^2}{1.27 \text{ in}^2/\text{bar}} = 4.27 \rightarrow 5 \text{ bars @ top \& bottom}$

Transverse Reinforcement:

21.5.3

$$\text{location} = 2(h) = 54''(2) = 108'' > l_n \text{ so over entire length}$$

$$\text{spacing} = \begin{array}{l|l} d/4 & = 54/4 = 13.5'' \\ 8d_b & = 10'' \leftarrow \text{controls} \\ 24d_t & = 24(5/8) = 15'' \\ \hline \text{min} & 12'' \end{array}$$

21.5.4.1

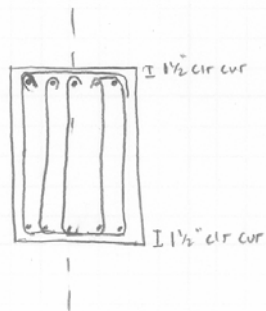

LL1 - LB - minimal reinforcement as deep beams

Check

Beam 91 = Group A : Floors (43-55)

$$M_{avg} = -4983 \text{ k-in}$$

$$O.B.M_{mix} = -5105 \text{ k-in} \leftarrow \text{controls design}$$

Wall construction

Flexural reinforcement

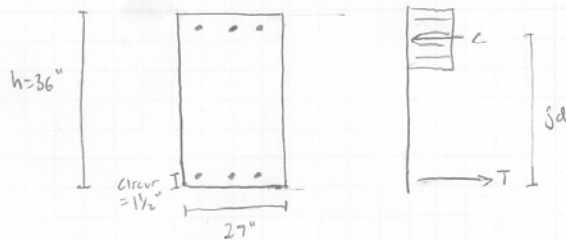

$$C = T \rightarrow 0.85 F'_c a h = A_s F_y$$

$$\phi M_n = A_s F_y j d$$

$$M_n = 0.9 (A_s F_y j d)$$

Try #10 bars

$$d = 36'' - 1\frac{1}{2}'' - 10\frac{1}{16}'' = 33\frac{7}{8}''$$

Assume $j d = 0.9 d$

$$\text{Solve for } A_s = \frac{M_n}{(0.9 F_y j d)} = \frac{5105 \text{ k-in}}{(0.9)(60)(0.9)(33\frac{7}{8}')} = 3.1 \text{ in}^2$$

\downarrow
3 #10s

$$a = \frac{A_s F_y}{0.85 (F'_c) (b)} = \frac{(3.1 \text{ in}^2)(60)}{(0.85)(6)(27')} = 1.35''$$

$$\text{calculate } j d = d - \frac{a}{2} = 33\frac{7}{8}'' - \frac{1.35 \text{ in}}{2} = 33.2''$$

Recalculate A_s :

$$\frac{(5105 \text{ k-in})}{(0.9)(60)(33.2')} = 2.85 \text{ in}^2$$

$$\text{Assume } (3) \#10 \text{ Bars} = 3(1.27) = 3.81 \text{ in}^2 = A_s$$

$$C = T \rightarrow a = \frac{(3.81 \text{ in}^2)(60 \text{ ksi})}{(0.85)(6 \text{ ksi})(27')} = 1.67 \text{ in}$$

$$c = \frac{1.67'}{0.85} = \frac{a}{\beta_1} = 1.96''$$

$$\epsilon_t = \epsilon_{cu} \left(\frac{d - c}{c} \right) \rightarrow (0.003) \left(\frac{33\frac{7}{8} - 1.96}{1.96} \right) = 0.049 > 0.005 \therefore \text{Tension controlled}$$

\checkmark OK

Shear reinforcement :

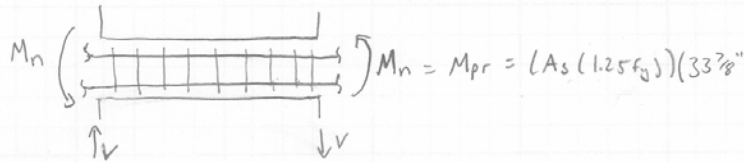

$$V = \frac{\sum M_{pr}}{l_n} = \frac{\sum M_{pr}}{84 \text{''}} = \frac{2(3.81 \text{ in}^2)(1.25(60))(33 \frac{3}{8} \text{''})}{84 \text{''}} = 230 \text{ k}$$

$$V_n = 230 \text{ k} < \phi V_n = \phi(V_c + V_s)$$

$$V_s = \frac{230 \text{ k} - 0.75(V_c)}{0.75} = \frac{230 \text{ k} - 0.75(27 \text{''})(36 \text{''})}{0.75} = 0$$

∴ use #4 @ max allowable spacing.

Group B: Lvl 9 - Lvl 38

$$M_{max} = -20,205 \text{ k-in}$$

$$0.8 M_{max} = -21,450 \text{ k-in} \leftarrow \text{controls}$$

Try #10 bars

$$A_s = \frac{M_u}{0.9 F_y j d} = \frac{21,450}{(0.9)(60)(0.9)(33 \frac{3}{8} \text{''})} = 13 \text{ in}^2 \text{ Too much}$$

Try #11 bars

$$d = 36 \text{''} - 1 \frac{1}{2} \text{''} - \frac{1}{16} \text{''} = 33.8125$$

$$A_s = \frac{21,450}{(0.9)(60)(0.9)(33.8125)} = 13.05 \text{ in}^2 = 8.3$$

$$a = \frac{A_s F_y}{0.85 F_c b} = \frac{(13.05)(60)}{(0.85)(6)(33)} = 4.65 \text{''}$$

$$j d = d - \frac{a}{2} = 33.8125 - \frac{4.65}{2} = 31.4875$$

Recalculate A_s :

$$A_s = \frac{21,450 \text{ k-in}}{0.9(60)(31.4875)} = \frac{12.6 \text{ in}^2}{1.56 \text{ in}^2} = 8.08 \text{ bars} \Rightarrow \begin{array}{l} 2 \text{ rows of } F(5) \#11 \text{ bars} \\ \text{or } 2 \text{ rows of } F(5) \#10 \text{ bars} \end{array}$$

by inspection

$$\epsilon_t = 0.0156 > 0.005 \text{ VOK Tension controlled}$$

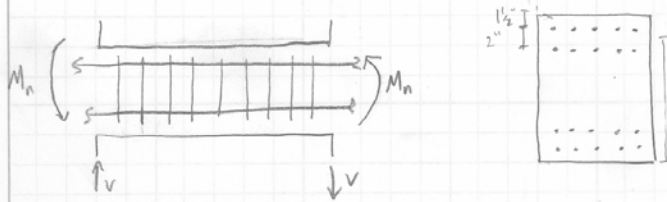

$$V = \frac{\sum M_{pr}}{L_n} = \frac{2(10)(1.27m)(1.25)(60)(36'' - 2 \times 1.5'' - 1.5'')}{39''} = 745.6''$$

$$V_n < \phi V_n \therefore 745.6'' < \phi(V_c + V_s)$$

$$V_s = \frac{745.6'' - 0.75(33'')(36'')}{0.75} = 0 \quad \therefore \text{Steel} = \#4 @ \text{max spacing}$$

Lower Level 1 - Level 7

Beam 91 - Level 6

$$M_{avg} = 39,435 \text{ ft-in} \quad F'_c = 10 \text{ ksi}$$

$$0.8 M_{max} = 40,515 \text{ ft-in} \quad F_y = 60 \text{ ksi}$$

Provide Minimum reinforcement based on ACI eq 10-3 & $\frac{200 \text{ bwd}}{\sqrt{F'_c}}$ on bottom of beam

Skin reinforcement:

$$S = (15) \left(\frac{40,000}{F_y} \right) - 2.5 c_c \quad \begin{matrix} F_y = 40,000 \text{ psi} \\ \text{for } F_y = 60 \text{ ksi} \end{matrix}$$

$c_c = 1.5''$ maintained from original design

$$S = (15) - 2.5(1.5) = 11.25''$$

Lower Level 1 - Level 7 require #4 spaced @ 11.25" skin reinforcement, use 10"

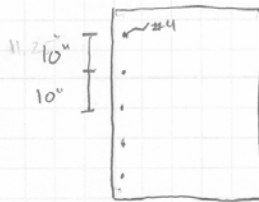

Beam 92

Group C: Floors (43-55)

Assume #10's

$$A_s = \frac{M_u}{0.9 F_y \cdot j \cdot d} = \frac{7507 \text{ k-in}}{(0.9)(60)(33\frac{7}{8})(.9)} = 4.56 \text{ in}^2$$

$$a = \frac{A_s F_y}{0.85 F_c b} = \frac{4.56(60)}{0.85(6)(27)} = 1.99 \text{ in}$$

$$\text{Calc. } j \cdot d = 33\frac{7}{8} - \frac{1.99}{2} = 32.9 \text{ in}$$

Recalculate A_s :

$$\frac{7,507}{0.9(60)(32.9)} = 4.23 \text{ in}^2 / 1.27 = (4) \#10's$$

$$\text{Assume } (4) \#10 \text{ bars} = 4(1.27) = 5.08 \text{ in}^2$$

$$c = T \rightarrow a = \frac{5.08 \text{ in}^2 (60 \text{ ksi})}{(0.85)(6)(27)} = 2.21 \text{ in}$$

$$c = \frac{a}{\beta_1} = \frac{2.21 \text{ in}}{0.85} = 2.6 \text{ in}$$

$$\epsilon_t = \epsilon_{cu} \left(\frac{d_c - c}{c} \right) \rightarrow 0.003 \left(\frac{33\frac{7}{8} - 2.6}{2.6} \right) = 0.036 > 0.005 \checkmark$$

Shear reinforcement:

$$V = \frac{\sum M_{pr}}{l_n} = \frac{2(5.08)(1.25)(60)(33\frac{7}{8})}{120} = 215 \text{ k}$$

$$V_u = 215 \text{ k} < \phi V_n = \phi(V_c + V_s)$$

$$V_s = \frac{215 \text{ k} - 0.75(V_c)}{0.75} = \frac{215 \text{ k} - 0.75(27)(36)}{0.75} = 0$$

\therefore use #4's @ max spacing allowed

Group D: Lvl 9 - Lvl 38

$$M_{\text{ave}} = 23,828 \text{ k-in}$$

$$0.8 M_{\text{max}} = 23,968 \text{ k-in} \leftarrow \text{Controls}$$

Try #10 bars

$$A_s = \frac{M_u}{0.9 F_y \cdot j \cdot d} = \frac{23,968}{(0.9)(60)(0.9 \cdot 33\frac{7}{8})} = 14.56 \text{ in}^2$$

$$a = \frac{A_s F_y}{0.85 F_c b} = \frac{14.56 \text{ in}^2 (60)}{0.85 (6) (33)} = 5.19 \text{ in}^2$$

$$\text{Recalculate } j d = d - \frac{a}{2} = (33 \frac{1}{8} \text{ in} - \frac{5.19}{2}) = 31.28 \text{ in}$$

Recalculate A_s :

$$\frac{23,968}{0.9 (60) (31.28)} = 14.19 \text{ in}^2 / 1.27 = 11.18 = 12 \text{ bars}$$

$$\text{TRY #11's } \Rightarrow \frac{14.19 \text{ in}^2}{1.56} = 9.09 \Rightarrow 10 \text{ bars}$$

$$j d = (33 \frac{1}{8} \text{ in} - \frac{5.19}{2}) = 31.28 \text{ in}$$

$$2 \text{ rows of } (5) \text{ #11's} = 15.6 \text{ in}^2$$

$$\rho_{t,e} = 0.0125 > 0.005 \sqrt{f_c}$$

Shear reinforcement:

$$V = \frac{\sum M_{pr}}{l_n} = \frac{2(15.6)(1.25)(60)(36 - 2 \frac{1}{2} - \frac{1}{16})}{120 \text{ in}} = 640 \text{ k}$$

$$V_s = \frac{640 \text{ k} - 0.75(33)(36 \text{ in}^2)}{0.75} = 0 \Rightarrow \text{Steel} = \#4 @ \text{max spacing.}$$

Story	Beam	Load	Loc	P	V2	M3	In	h	f'c	fy	b	ln/h	(ln/h)>4	(ln/h)<2	4N(f'c)Acw	Vu>4N(f'c)Acw	Eqn 10-3	As, min	200bwdf/y	p=0.25	As	Controlling	#8 bars	#9 bars	#10 bars	#11 bars	φMn
L36	B91	DLWEAST		84	0	256.47	-10587.6	84	36	6	60	33	2.333333	n	11639.97526	n	4.369451	3.760625	29.7	4.369	6	5	4	3	941070		
L9	B91	DLWEAST		84	0	493.7	-20606.3	84	36	8	60	33	2.333333	n	13440.6857	n	5.045408	3.760625	29.7	5.045	7	6	4	4	941070		
L7	B91	DLWEAST		84	0	1211.92	-50101.2	84	96	10	60	36	0.875	y	43715.32637	n	16.95375	11.3025	86.4	16.954	22	17	14	11	3613785		
L6	B91	DLWEAST		84	0	1232.48	-50643.4	84	132	10	60	36	0.636364	y	60108.57376	n	23.43375	15.6225	118.8	23.434	30	24	19	16	4904422		
L5	B91	DLWEAST		84	0	1023.1	-41886	84	132	10	60	36	0.636364	y	60108.57376	n	23.43375	15.6225	118.8	23.434	30	24	19	16	4904422		
L4	B91	DLWEAST		84	0	847.83	-35164.2	84	60	10	60	36	1.4	y	27322.07898	n	10.47375	6.9825	54	10.474	14	11	9	7	2323147		
L2	B91	DLWEAST		84	0	942.06	-38797.8	84	92	10	60	36	0.913043	y	41893.85444	n	16.23375	10.8225	82.8	16.234	21	17	13	11	3355565		
L1	B91	DLWEAST		84	0	850.89	-34855.7	84	104	10	60	36	0.807692	y	47358.27024	n	18.39375	12.2625	93.6	18.394	24	19	15	12	3871912		
L11	B91	DLWEAST		84	0	606.99	-24593.9	84	104	10	60	36	0.807692	y	47358.27024	n	18.39375	12.2625	93.6	18.394	24	19	15	12	3871912		

Appendix D : Pier Design: Shear & Flexure

Pier 4

$0.9D + 1.6W :$

LL 1:

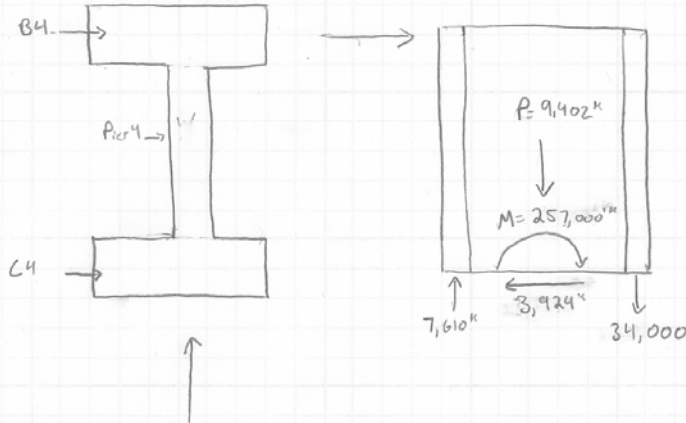

Pier 4 :

$$11.9.6 \text{ \& } \text{check} \left(\frac{M_u}{V_u} - \frac{d_w}{2} \right)$$

$$= \frac{257,000 \text{ in-k}}{3,924 \text{ k}} - \frac{477 \text{ in}}{2}$$

$$= 45.6' = 546.7'' > 0$$

∴ check 11-27 & 11-28 & use minimum

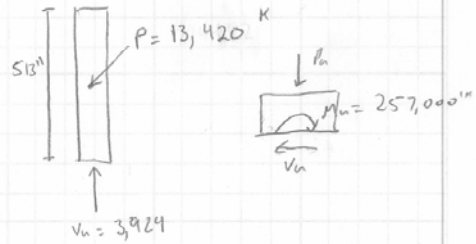

11-27: $V_c = 3.3 \lambda \sqrt{f'_c} h d + \frac{N_u d}{4 l_w}$

11-28: $V_c = \left[0.6 \lambda \sqrt{f'_c} + \frac{l_w \left(1.25 \lambda \sqrt{f'_c} + 0.2 \frac{N_u}{l_w h} \right)}{\frac{M_u}{V_u} - \frac{d_w}{2}} \right] h d$

From 11.9.4 $d = 0.8 l_w$
 $d = 0.8 (477)$
 $= 382''$

$\lambda = 1$

$$11-27 \quad V_c = \frac{3.3 \sqrt{40,000} (222") (382")}{1000} + \frac{13,421 (382")}{4 (477")} = 30,672^k$$

$$11-28 \quad V_c = \left[\frac{0.6 \sqrt{40,000} + \frac{477" (1.25 \sqrt{40,000} + 0.2 \frac{(13,421 \times 1000)}{477" (288")})}{546.7"}{1000} \right] (288)(382)$$

$$V_c = 14,319.7^k \quad \leftarrow \text{controls}$$

$$\phi V_c = 0.75 (14,319.7^k) = 10,739.74^k$$

$$\frac{V_u}{\phi V_c} = \frac{3,923.98}{10,740^k} = 0.365 < 0.5 \quad \therefore \text{Can use 11.9.9 or chpt 14}$$

Chapter 14 =

14.3.2 Minimum vertical reinforcement ρ_v for bars $\leq \#5$

$$\rho_v = 0.0012$$

$$A_{s,min} = 0.0012 (b \times h) = 0.0012 (27" \times 477") = \frac{15.45 \text{ in}^2}{2 \text{ rows} \times (0.31)} = 19"$$

\therefore use #5's @ 18" \rightarrow make it #5 @ 12"

14.3.3 Minimum ratio of horizontal reinforcement

$$\rho_h = 0.0025$$

$$A_{s,min} = (0.0025) (b \times h) = 0.0025 (27" \times 222") = 14.99 \text{ in}^2$$

$$\frac{14.99 \text{ in}^2}{2 \text{ rows} \times (0.49)} = 15.3" \quad \therefore \text{use #6's @ 12"}_{\text{min}}$$

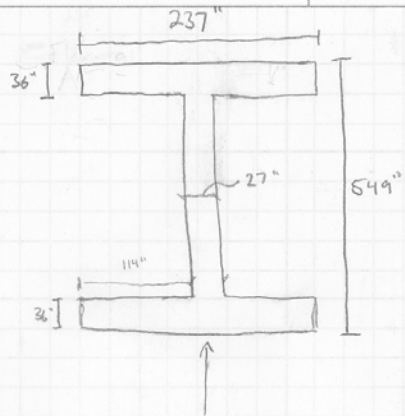

Pier 4: LL

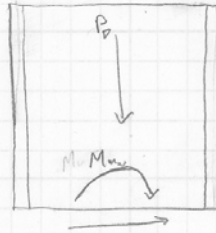

$$M_{uw} = 11,209,324 \text{ in}^2\text{-k}$$

$$P_u = 0.9 P_D =$$

$$LC = P = 26270, M = \pm 943,110$$

$$A_s = \left(\frac{M}{\phi_c} - 0.9 P_D \right) / 0.9 f_y$$

$$M \leq 0.9 P_D = 13,135 \text{ kips}$$

$$\text{Check } A_{s, \text{req}} = \left(\frac{11,209,324 \text{ in}^2\text{-k}}{0.9 (549)} - 13,135 \right) / (0.9 \times 60 \text{ ksi})$$

$$= 177 \text{ in}^2$$

$$\# \frac{A_{s, \text{shear req}} = 24 \text{ in}^2}{153 \text{ in}^2}$$

$$\frac{153 \text{ in}^2}{21.56} = 98 \# 11's = 3 \text{ rows of } \# 11 @ \frac{257}{33} = 7.18 \text{ i. } @ 6" \text{ o.c.}$$

$$\frac{153 \text{ in}^2}{2.25} = 68 \# 14's = 2 \text{ rows of } \# 14 @ \frac{237}{34} = 6" \text{ o.c.}$$

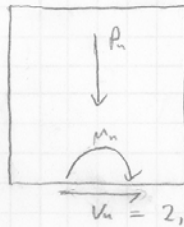
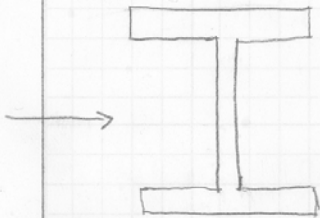

$$P_u = -25,188 \text{ k} + 26,270 = 1082$$

$$M_u = 1,008,627$$

$$A_s = \left(\frac{M}{\phi_c} - 0.9 P \right) / 0.9 f_y = \left(\frac{1,008,627 \text{ in}^2\text{-k}}{0.8 (237)} - \frac{1082}{2} \right) / (0.9 \times 60 \text{ ksi})$$

$$= 89 \text{ in}^2 < 2(59) \text{ provided by NS bending req}$$

$$LC = P = 51458, M = -84973$$

$$P = 1082, 84793$$

PCA Column way:

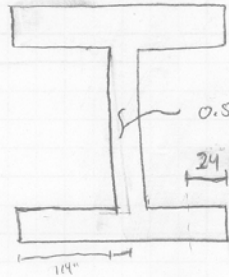

$$0.5\% A_w @ 1' = \frac{0.05(47)(27)}{\left(\frac{47}{12}\right)} = \frac{64.4 \text{ in}^2}{4.79} = 162 \text{ in}^2$$

B.E. Reinforcement

ACI 318-08 21.9.6.5 - Special boundary elements are not required by 21.6.4.2 or 21.9.6.3;
 ∴ a & b shall be satisfied.

a) longitudinal reinforcement ratio = $\frac{6(1.56)}{(24)(36)} = 0.0108 = \rho_{BE}$

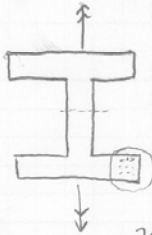

$$400/f_y = 400/60,000 = 0.0067 < \rho_{BE}$$

∴ Design by 21.6.4.2 & 21.9.6.4(a)

21.6.4.2 = hoops spacing $h_x < 14"$

N.A.:

$$c = \frac{A_s f_y}{(0.85)(0.85)(f'_c)(b)} = \frac{88(60)}{0.85^2(10)(72)} = 10.2"$$

$$c = 0.1d_w = 10.2 - 0.1(237) \approx 2.3" \leftarrow \text{controls}$$

$c/2 > 5.1" \Rightarrow$ use 0.15 d_w for good design

b)

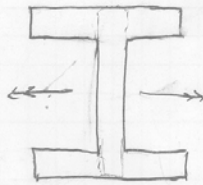
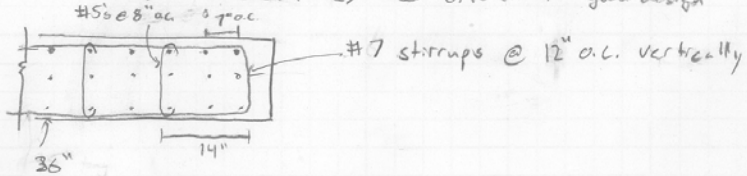

$$c = \frac{A_s f_y}{0.85^2(10)(237)} = \frac{177 \text{ in}^2(60)}{0.85^2(10)(237)} = 6.2" \Rightarrow \text{use } 12" \text{ by good design practice}$$

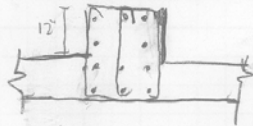

Column PM Interaction Diagrams

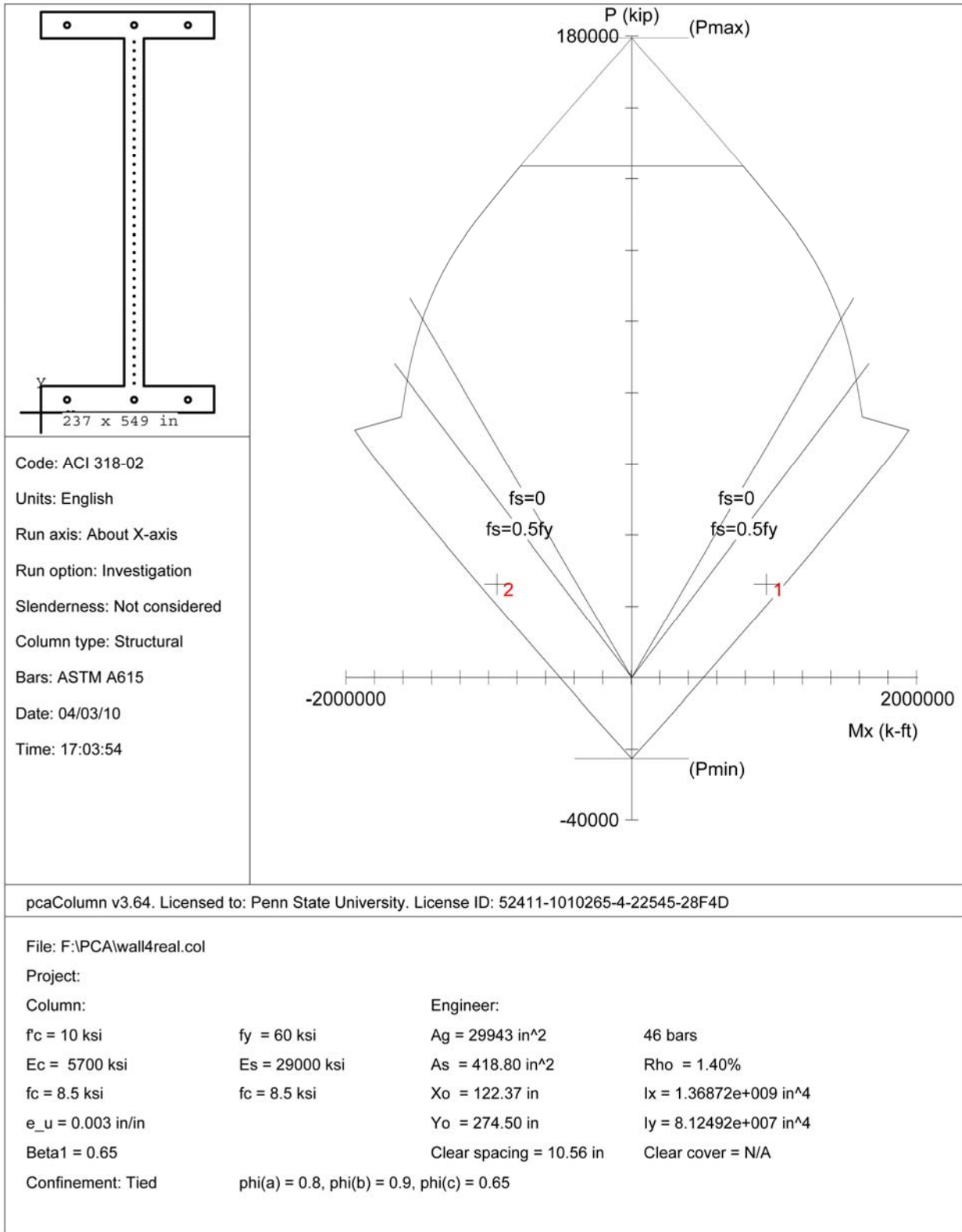

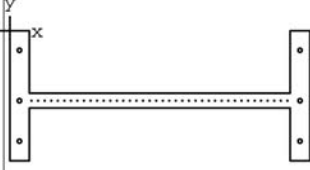

549 x 237 in

Code: ACI 318-02
 Units: English
 Run axis: About X-axis
 Run option: Investigation
 Slenderness: Not considered
 Column type: Structural
 Bars: ASTM A615
 Date: 04/03/10
 Time: 17:12:46

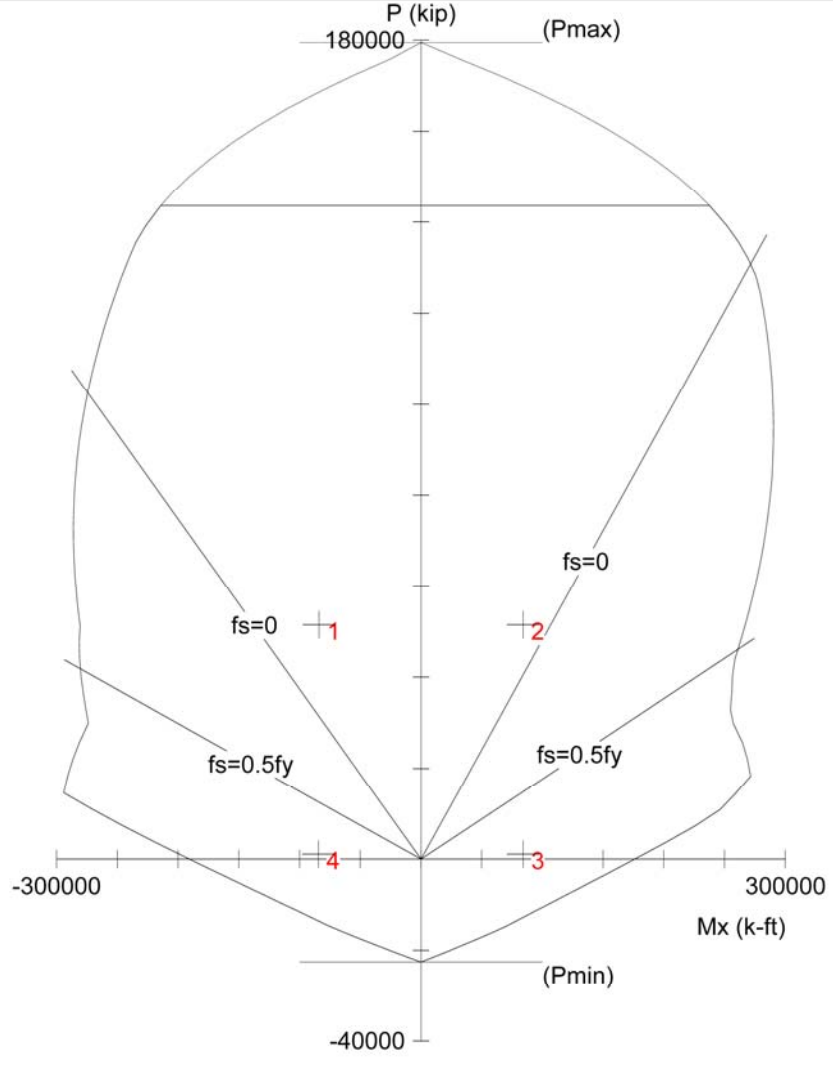

pcaColumn v3.64. Licensed to: Penn State University. License ID: 52411-1010265-4-22545-28F4D

File: F:\PCA\wall4realabouty.col

Project:

Column:

$f_c = 10$ ksi

$E_c = 5700$ ksi

$f_c = 8.5$ ksi

$e_u = 0.003$ in/in

Beta1 = 0.65

Confinement: Tied

$f_y = 60$ ksi

$E_s = 29000$ ksi

$f_c = 8.5$ ksi

$\phi(a) = 0.8, \phi(b) = 0.9, \phi(c) = 0.65$

Engineer:

$A_g = 29943$ in²

$A_s = 418.80$ in²

$X_o = 274.50$ in

$Y_o = -122.37$ in

Clear spacing = 10.56 in

46 bars

Rho = 1.40%

$I_x = 8.12492e+007$ in⁴

$I_y = 1.36872e+009$ in⁴

Clear cover = N/A

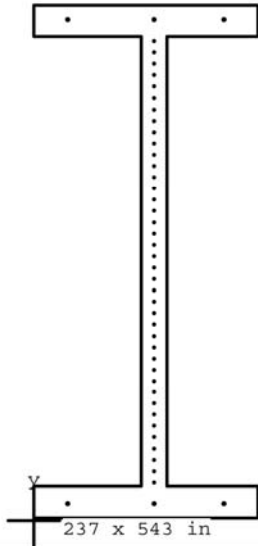

Code: ACI 318-02
 Units: English
 Run axis: About X-axis
 Run option: Investigation
 Slenderness: Not considered
 Column type: Structural
 Bars: ASTM A615
 Date: 04/06/10
 Time: 00:38:56

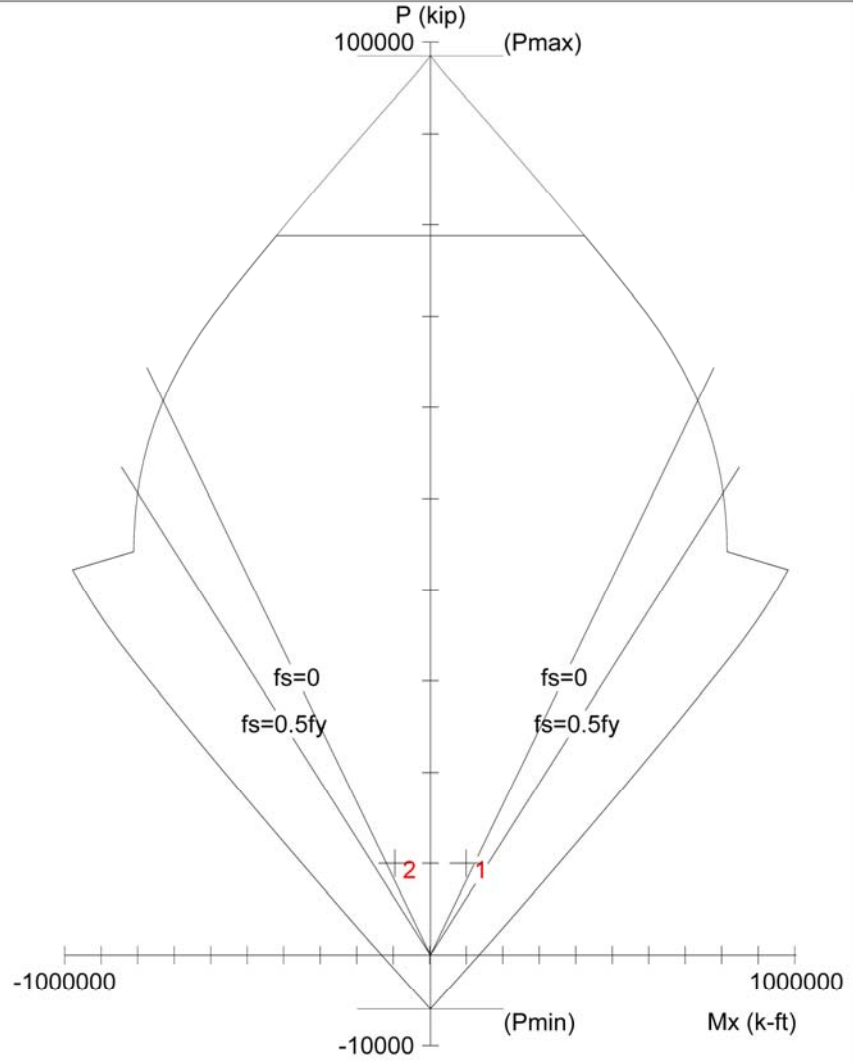

pcaColumn v3.64. Licensed to: Penn State University. License ID: 52411-1010265-4-22545-28F4D

File: F:\PCA\wall4reallv136.col

Project:

Column:

$f_c = 6$ ksi

$E_c = 4415$ ksi

$f_c = 5.1$ ksi

$e_u = 0.003$ in/in

Beta1 = 0.75

Confinement: Tied

$f_y = 60$ ksi

$E_s = 29000$ ksi

$f_c = 5.1$ ksi

$\phi(a) = 0.8, \phi(b) = 0.9, \phi(c) = 0.65$

Engineer:

$A_g = 28521$ in²

$A_s = 110.40$ in²

$X_o = 122.56$ in

$Y_o = 274.50$ in

Clear spacing = 10.56 in

46 bars

Rho = 0.39%

$I_x = 1.26274e+009$ in⁴

$I_y = 7.45708e+007$ in⁴

Clear cover = N/A

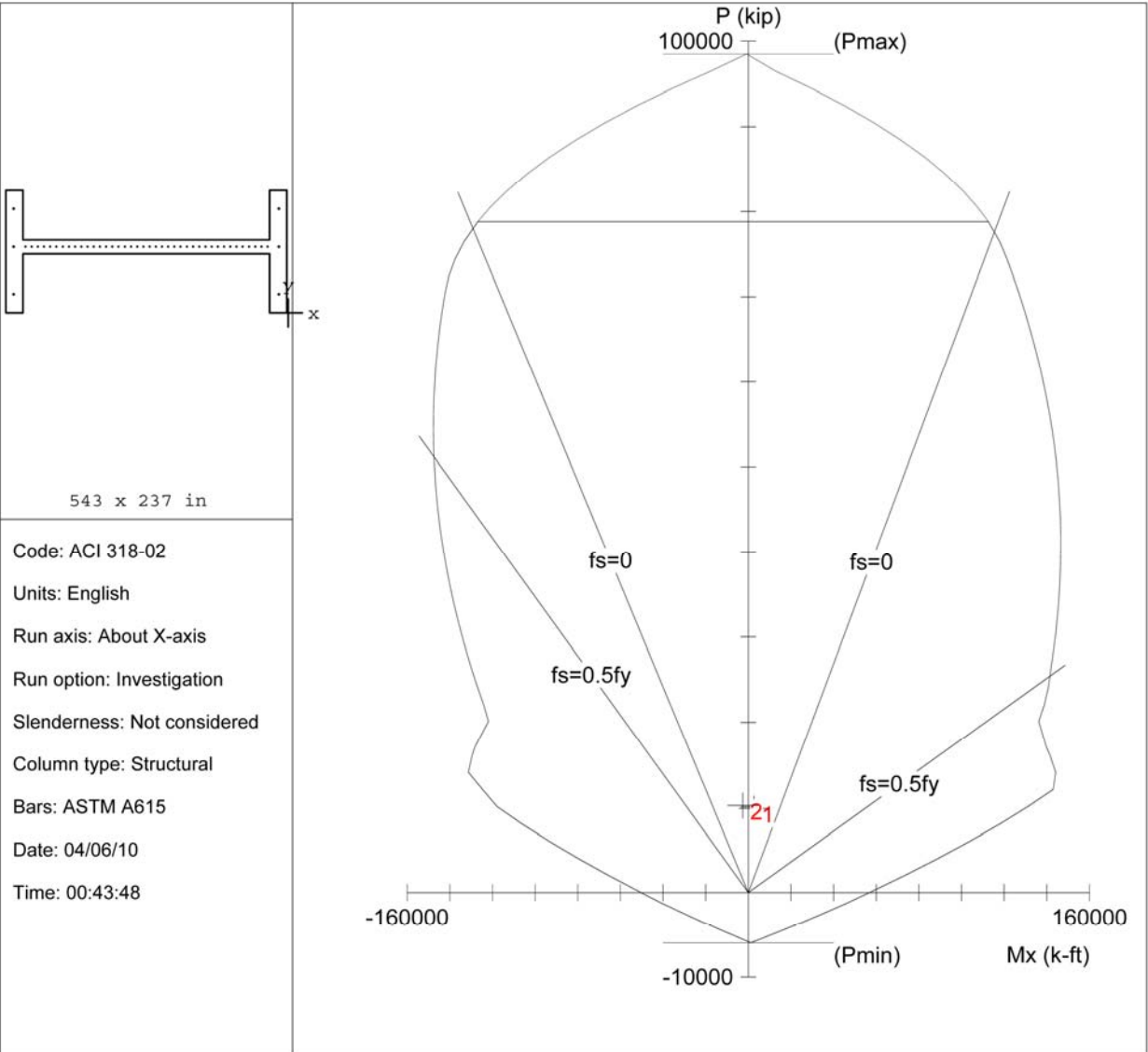

543 x 237 in

Code: ACI 318-02
 Units: English
 Run axis: About X-axis
 Run option: Investigation
 Slenderness: Not considered
 Column type: Structural
 Bars: ASTM A615
 Date: 04/06/10
 Time: 00:43:48

pcaColumn v3.64. Licensed to: Penn State University. License ID: 52411-1010265-4-22545-28F4D

File: F:\PCA\wall4reallv136.col

Project:

Column:

$f_c = 6$ ksi
 $E_c = 4415$ ksi
 $f_c = 5.1$ ksi
 $e_u = 0.003$ in/in
 $\text{Beta}1 = 0.75$
 Confinement: Tied

$f_y = 60$ ksi
 $E_s = 29000$ ksi
 $f_c = 5.1$ ksi
 $\phi(a) = 0.8, \phi(b) = 0.9, \phi(c) = 0.65$

Engineer:

$A_g = 28521$ in²
 $A_s = 110.40$ in²
 $X_o = -274.50$ in
 $Y_o = 122.56$ in
 Clear spacing = 10.56 in

46 bars
 $\text{Rho} = 0.39\%$
 $I_x = 7.45706e+007$ in⁴
 $I_y = 1.26274e+009$ in⁴
 Clear cover = N/A

Appendix E: Lateral Drifts

Seismic Drift

Further calculations can be provided by the author upon request.

Seismic Drift Analysis										
Story	Story Height (in)	East - West Drift				North-South Drift				
		delta max	delta avg	Actual Drift (in)	Allowable 0.02hsx (in)	delta avg	delta max	Actual Drift (in)	Allowable 0.02hsx (in)	
L60	150	12.96	13.04	0.0028	3.00	14.12	17.12	0.0036	3	
L59(ROOF)	120	12.74	12.84	0.0028	2.40	13.84	16.24	0.0036	2.4	
L58	168	12.58	12.67	0.0028	3.36	13.62	16.98	0.0036	3.36	
L57	174	12.34	12.43	0.0029	3.48	13.32	16.80	0.0036	3.48	
L56	174	12.09	12.18	0.0029	3.48	13.00	16.48	0.0036	3.48	
L55	174	11.84	11.93	0.0030	3.48	12.68	16.16	0.0036	3.48	
L54	156	11.58	11.67	0.0030	3.12	12.36	15.48	0.0036	3.12	
L53	156	11.34	11.43	0.0031	3.12	12.08	15.20	0.0036	3.12	
L52	156	11.10	11.19	0.0031	3.12	11.79	14.91	0.0036	3.12	
L51	156	10.85	10.95	0.0031	3.12	11.51	14.63	0.0036	3.12	
L50	156	10.61	10.71	0.0032	3.12	11.23	14.35	0.0036	3.12	
L49	156	10.36	10.46	0.0032	3.12	10.95	14.07	0.0036	3.12	
L48	156	10.12	10.21	0.0032	3.12	10.67	13.79	0.0035	3.12	
L47	156	9.87	9.97	0.0032	3.12	10.39	13.51	0.0035	3.12	
L46	156	9.62	9.72	0.0031	3.12	10.12	13.24	0.0035	3.12	
L45	156	9.38	9.48	0.0031	3.12	9.85	12.97	0.0034	3.12	
L44	156	9.14	9.24	0.0030	3.12	9.58	12.70	0.0034	3.12	
L43	156	8.91	9.01	0.0033	3.12	9.31	12.43	0.0035	3.12	
L42	144	8.65	8.77	0.0025	2.88	9.04	11.92	0.0035	2.88	
L41	168	8.48	8.22	0.0026	3.36	8.50	11.86	0.0037	3.4	
L39	156	8.25	7.96	0.0029	3.12	8.18	11.30	0.0034	3.12	
L38	156	8.03	7.73	0.0030	3.12	7.92	11.04	0.0034	3.12	
L37	156	7.80	7.50	0.0031	3.12	7.65	10.77	0.0035	3.12	
L36	156	7.56	7.26	0.0031	3.12	7.38	10.50	0.0035	3.12	
L35	156	7.32	7.01	0.0032	3.12	7.11	10.23	0.0035	3.12	
L34	156	7.07	6.76	0.0032	3.12	6.84	9.96	0.0035	3.12	
L33	156	6.82	6.51	0.0032	3.12	6.56	9.68	0.0035	3.12	
L32	156	6.57	6.26	0.0032	3.12	6.28	9.40	0.0035	3.12	
L31	156	6.32	6.01	0.0033	3.12	6.01	9.13	0.0035	3.12	
L30	156	6.06	5.76	0.0033	3.12	5.73	8.85	0.0035	3.12	
L29	156	5.81	5.50	0.0033	3.12	5.45	8.57	0.0035	3.12	
L28	156	5.55	5.25	0.0033	3.12	5.18	8.30	0.0035	3.12	
L27	156	5.29	4.99	0.0034	3.12	4.90	8.02	0.0035	3.12	
L26	156	5.03	4.73	0.0034	3.12	4.63	7.75	0.0034	3.12	
L25	156	4.77	4.46	0.0034	3.12	4.36	7.48	0.0034	3.12	
L24	156	4.50	4.20	0.0034	3.12	4.09	7.21	0.0033	3.12	
L23	156	4.24	3.94	0.0034	3.12	3.83	6.95	0.0033	3.12	
L22	156	3.97	3.68	0.0034	3.12	3.57	6.69	0.0032	3.12	
L21	156	3.71	3.43	0.0033	3.12	3.32	6.44	0.0032	3.12	
L20	156	3.45	3.17	0.0033	3.12	3.07	6.19	0.0031	3.12	
L19	156	3.19	2.92	0.0033	3.12	2.82	5.94	0.0030	3.12	
L18	156	2.94	2.67	0.0032	3.12	2.58	5.70	0.0029	3.12	
L17	156	2.69	2.43	0.0031	3.12	2.35	5.47	0.0028	3.12	
L16	156	2.44	2.19	0.0031	3.12	2.13	5.25	0.0027	3.12	
L15	156	2.20	1.96	0.0030	3.12	1.92	5.04	0.0026	3.12	
L14	156	1.97	1.74	0.0029	3.12	1.71	4.83	0.0025	3.12	
L13	156	1.74	1.53	0.0028	3.12	1.51	4.63	0.0024	3.12	
L12	156	1.53	1.32	0.0027	3.12	1.32	4.44	0.0022	3.12	
L11	156	1.32	1.12	0.0025	3.12	1.15	4.27	0.0021	3.12	
L10	156	1.12	0.94	0.0024	3.12	0.98	4.10	0.0019	3.12	
L9	156	0.93	0.77	0.0022	3.12	0.83	3.95	0.0018	3.12	
L7	216	0.76	0.57	0.0019	4.32	0.69	5.01	0.0016	4.32	
L6	252	0.56	0.38	0.0015	5.04	0.52	5.56	0.0014	5.04	
L5	156	0.37	0.28	0.0013	3.12	0.34	3.46	0.0011	3.12	
L4	180	0.27	0.19	0.0011	3.60	0.25	3.85	0.0010	3.6	
L2	212	0.17	0.10	0.0009	4.24	0.16	4.40	0.0007	4.24	
L1	244	0.08	0.03	0.0006	4.88	0.09	4.97	0.0005	4.88	

Wind Factors, Coefficients, Loads, and Drift

Factors and Coefficients		
	North/ South	East/ West
V	90	90
Kd	0.85	0.85
l	1.00	1.00
Exposure	B	B
Kzt	1.00	1.00
Kh	1.78	1.78
α	7.00	7.00
Zg	1200.00	1200.00
z	796.00	796.00
B	199.50	133.25
L	133.25	199.50
h	786.00	786.00
g _Q	3.40	3.40
g _v	3.40	3.40
g _R	3.92	3.92
η ₁	0.34	0.34
z _{bar}	471.60	471.60
lz _{bar}	0.19	0.19
Lz _{bar}	776.55	776.55
Q	0.76	0.77
V _{bar} z	115.49	115.49
N ₁	2.26	2.26
R _n	0.08	0.08
R _h	0.09	0.09
R _B	0.30	0.41
R _i	0.15	0.11
R	0.37	0.42
Gf	0.86	0.88
Windward Cp	0.80	0.80
Leeward Cp	-0.50	-0.50
Parapet Windward		
GC _{pn}	1.50	1.50
Parapet Leeward GC _{pn}	-1.00	-1.00

East / West Wind Forces			
Story Level	Story Height (ft)	Story Force (Kips)	Moment (k-ft)
Roof	786.00	0.0	95477
58	772.00	87.7	67735
57	757.50	89.3	67629
56	743.00	88.5	65746
55	728.50	83.9	61119
54	715.50	79.3	56754
53	702.50	79.1	55558
52	689.50	78.6	54167
51	676.50	78.6	53146
50	663.50	78.6	52125
49	650.50	78.2	50862
48	637.50	77.8	49570
47	624.50	77.8	48559
46	611.50	77.8	47548
45	598.50	77.2	46223
44	585.50	76.9	45027
43	572.50	73.9	42334
42	560.50	76.9	43105
41	546.50	82.5	45077
40	532.33	79.3	42209
39	519.33	75.9	39409
38	506.33	75.9	38417
37	493.33	75.0	37021
36	480.33	75.0	36045
35	467.33	75.0	35070
34	454.33	74.9	34014
33	441.33	74.0	32654
32	428.33	74.0	31692
31	415.33	74.0	30730
30	402.33	73.6	29605
29	389.33	72.7	28314
28	376.33	72.7	27369
27	363.33	72.7	26423
26	350.33	72.1	25268
25	337.33	71.5	24106
24	324.33	71.5	23177
23	311.33	71.5	22248
22	298.33	70.5	21043
21	285.33	70.0	19970
20	272.33	70.0	19060
19	259.33	70.0	18150
18	246.33	68.7	16915
17	233.33	68.3	15937
16	220.33	68.3	15049
15	207.33	68.3	14161
14	194.33	67.7	13158
13	181.33	67.3	12210
12	168.33	66.8	11249
11	155.33	66.1	10268
10	142.33	65.6	9344
9	129.33	77.4	10013
7	111.33	95.8	10671
6	90.33	82.4	7448
5	77.33	66.8	5163
4	62.33	76.1	4746
2	44.67	82.3	3677
1	26.00	80.9	2104
LL-1	7.5	70.9	532
Total Base Shear (kips)= 4294.1			
Total Overturning Moment (k-ft)= 1852401			

North / South Wind Forces			
Story Level	Story Height (ft)	Shear Force (Kips)	Moment (k-ft)
Roof	786.00	0.0	144437
58	772.00	133.4	102992
57	757.50	135.7	102830
56	743.00	134.5	99962
55	728.50	127.6	92927
54	715.50	120.6	86291
53	702.50	120.2	84472
52	689.50	119.4	82354
51	676.50	119.4	80801
50	663.50	119.4	79249
49	650.50	118.9	77327
48	637.50	118.2	75360
47	624.50	118.2	73824
46	611.50	118.2	72287
45	598.50	117.4	70270
44	585.50	116.9	68450
43	572.50	112.4	64356
42	560.50	116.9	65528
41	546.50	125.4	68522
40	532.33	120.5	64161
39	519.33	115.4	59906
38	506.33	115.3	58398
37	493.33	114.1	56272
36	480.33	114.1	54789
35	467.33	114.1	53306
34	454.33	113.8	51701
33	441.33	112.5	49630
32	428.33	112.5	48168
31	415.33	112.5	46706
30	402.33	111.8	44995
29	389.33	110.5	43031
28	376.33	110.5	41594
27	363.33	110.5	40157
26	350.33	109.6	38399
25	337.33	108.6	36632
24	324.33	108.6	35220
23	311.33	108.6	33809
22	298.33	107.2	31975
21	285.33	106.3	30342
20	272.33	106.3	28960
19	259.33	106.3	27577
18	246.33	104.3	25699
17	233.33	103.8	24212
16	220.33	103.8	22863
15	207.33	103.8	21514
14	194.33	102.9	19989
13	181.33	102.3	18548
12	168.33	101.5	17088
11	155.33	100.4	15596
10	142.33	99.7	14192
9	129.33	117.6	15207
7	111.33	145.5	16205
6	90.33	125.2	11309
5	77.33	101.4	7839
4	62.33	115.6	7204
2	44.67	125.0	5581
1	26.00	122.8	3193
LL-1	7.5	107.6	807
Total Base Shear (kips)= 6525.5			
Total Overturning Moment (k-ft)= 2815015			

Wind Drift vs. Recommended Drift for Serviceability							
Story	Height (in)	Wind E-W			Wind N-S		
		Ux (in)	H/400 (in)	% Allowable	Uy (in)	H/400 (in)	% Allowable
L60	9702	13.13	24.26	46%	22.26	24.26	8%
L59	9552	12.91	23.88	46%	21.78	23.88	9%
L58(Roof)	9432	12.75	23.58	46%	21.43	23.58	9%
L57	9264	12.51	23.16	46%	20.95	23.16	10%
L56	9090	12.27	22.73	46%	20.45	22.73	10%
L55	8916	12.02	22.29	46%	19.95	22.29	11%
L54	8742	11.76	21.86	46%	19.44	21.86	11%
L53	8586	11.53	21.47	46%	19.00	21.47	12%
L52	8430	11.30	21.08	46%	18.55	21.08	12%
L51	8274	11.06	20.69	47%	18.10	20.69	13%
L50	8118	10.82	20.30	47%	17.65	20.30	13%
L49	7962	10.58	19.91	47%	17.21	19.91	14%
L48	7806	10.34	19.52	47%	16.76	19.52	14%
L47	7650	10.09	19.13	47%	16.32	19.13	15%
L46	7494	9.85	18.74	47%	15.88	18.74	15%
L45	7338	9.61	18.35	48%	15.45	18.35	16%
L44	7182	9.38	17.96	48%	15.02	17.96	16%
L43	7026	9.15	17.57	48%	14.59	17.57	17%
L42	6870	9.11	17.18	47%	14.18	17.18	17%
L40	6558	8.70	16.40	47%	13.36	16.40	19%
L39	6388	8.30	15.97	48%	12.92	15.97	19%
L38	6232	8.08	15.58	48%	12.49	15.58	20%
L37	6076	7.84	15.19	48%	12.06	15.19	21%
L36	5920	7.61	14.80	49%	11.63	14.80	21%
L35	5764	7.36	14.41	49%	11.19	14.41	22%
L34	5608	7.12	14.02	49%	10.76	14.02	23%
L33	5452	6.87	13.63	50%	10.32	13.63	24%
L32	5296	6.62	13.24	50%	9.88	13.24	25%
L31	5140	6.37	12.85	50%	9.44	12.85	27%
L30	4984	6.12	12.46	51%	9.00	12.46	28%
L29	4828	5.86	12.07	51%	8.57	12.07	29%
L28	4672	5.61	11.68	52%	8.13	11.68	30%
L27	4516	5.35	11.29	53%	7.70	11.29	32%
L26	4360	5.09	10.90	53%	7.27	10.90	33%
L25	4204	4.83	10.51	54%	6.85	10.51	35%
L24	4048	4.56	10.12	55%	6.43	10.12	36%
L23	3892	4.30	9.73	56%	6.02	9.73	38%
L22	3736	4.04	9.34	57%	5.62	9.34	40%
L21	3580	3.77	8.95	58%	5.22	8.95	42%
L20	3424	3.51	8.56	59%	4.83	8.56	44%
L19	3268	3.26	8.17	60%	4.45	8.17	46%
L18	3112	3.00	7.78	61%	4.07	7.78	48%
L17	2956	2.75	7.39	63%	3.71	7.39	50%
L16	2800	2.50	7.00	64%	3.36	7.00	52%
L15	2644	2.26	6.61	66%	3.03	6.61	54%
L14	2488	2.02	6.22	67%	2.70	6.22	57%
L13	2332	1.79	5.83	69%	2.39	5.83	59%
L12	2176	1.57	5.44	71%	2.10	5.44	61%
L11	2020	1.36	5.05	73%	1.82	5.05	64%
L10	1864	1.17	4.66	75%	1.56	4.66	66%
L9	1708	0.98	4.27	77%	1.32	4.27	69%
L7	1552	0.82	3.88	79%	1.10	3.88	72%
L6	1336	0.63	3.34	81%	0.82	3.34	75%
L5	1084	0.43	2.71	84%	0.55	2.71	80%
L4	928	0.32	2.32	86%	0.40	2.32	83%
L2	748	0.22	1.87	88%	0.26	1.87	86%
L1	536	0.11	1.34	92%	0.13	1.34	90%
LL1	312	0.03	0.78	96%	0.04	0.78	95%

Appendix F:

Additional spreadsheets involved in the previous calculations, as well as relative stiffness confirmation of the model can be provided by the author upon request.